

Domekt R 400 F

Maximal air flow, m ³ /h	472
Panel thickness, mm	50
Unit weight, kg	67
Supply voltage, V	1~230
Maximal operating current, A	HE 7,3
Thermal efficiency of heat recovery, %	81
Reference flow rate, m ³ /s	0,092
Reference pressure difference, Pa	50
SPI, W/(m ³ /h)	0,43
Filters dimensions BxHxL, mm	278x258x46-M5
Electric power input of the fan drive at reference flow rate, W	72
Electric power input of the fan drive at maximum flow rate, W	165
Electric air heater capacity, kW / Δt, °C	1 / 8,4
Control panel	C6.1 / C6.2
Maintenance space, mm	300

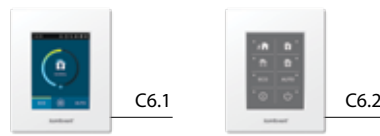
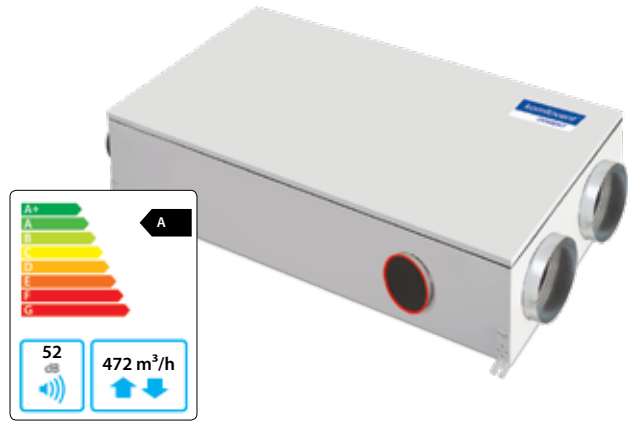

The photo is intended for informational purposes only, exact details may vary.

Acoustic data

A-weighted sound power level L_{WA}, dB(A) at reference flow rate

Supply inlet	63
Supply outlet	72
Exhaust inlet	63
Exhaust outlet	72
Casing	52

A-weighted sound pressure level L_{PA}, dB(A) 10 m² normally isolated room, distance from casing – 3 m.

Surroundings	41
--------------	----

Performance

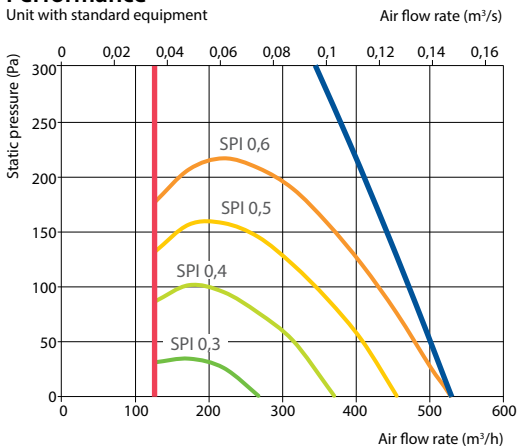

Temperature efficiency

Outside temperature, °C	Winter					Summer		
	-23	-15	-10	-5	0	25	30	35
After heat exchanger, °C	11,4	13,3	14,5	15,7	16,8	22,7	23,9	25,1

indoor +22°C, 20 % RH

Shown as right (R1)

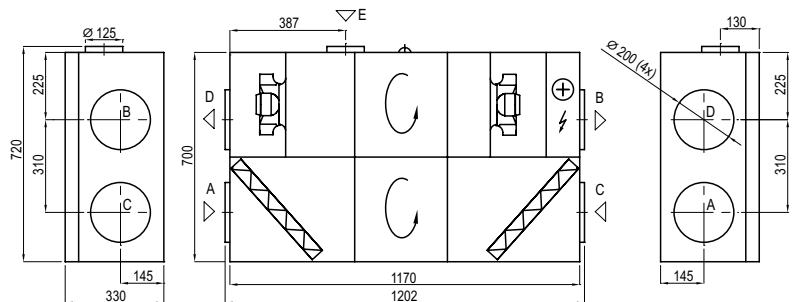

Shown as left (L1)

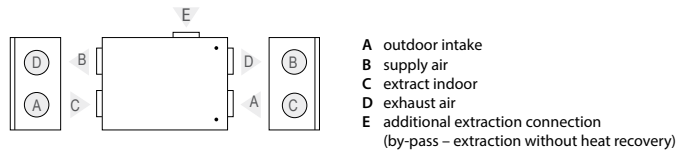

Accessories (p. 108)

Closing damper	AGUJ-M-200+LF230/LM230
Silencer	A/D AGS-200-50-600-M
	B/C AGS-200-50-900-M
Water heater	DH-200
PPU	PPU-HW-3R-15-0,63-W1

2-way valve (water heater)	VVP47.10-0,63
Air heater-cooler	DCW-0,4-3 / DHCW-200
2-way valve (water cooler)	VVP47.15-2,5
DX cooler	DCF-0,4-3