

# Domekt R 250 F

Maximal air flow, m <sup>3</sup> /h	250
Panel thickness, mm	50
Unit weight, kg	40
Supply voltage, V	1~230
Maximal operating current, A	HE 6,1
Thermal efficiency of heat recovery, %	80
Reference flow rate, m <sup>3</sup> /s	0,049
Reference pressure difference, Pa	50
SPI, W/(m <sup>3</sup> /h)	0,47
Filters dimensions BxHxL, mm	278x258x46-M5
Electric power input of the fan drive at reference flow rate, W	40
Electric power input of the fan drive at maximum flow rate, W	90
Electric air heater capacity, kW / Δt, °C	1 / 15,9
Control panel	C6.1 / C6.2
Maintenance space, mm	300

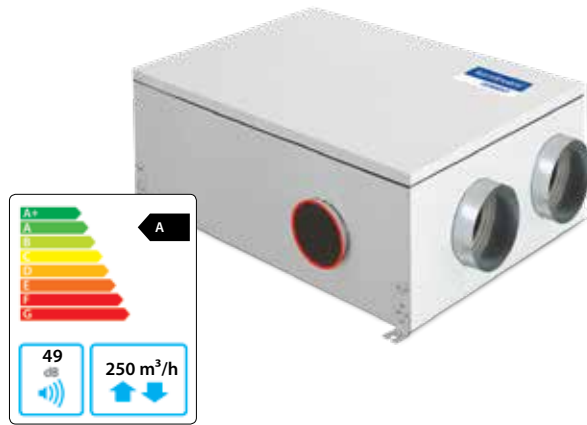

The photo is intended for informational purposes only, exact details may vary.

## Acoustic data

**A-weighted sound power level L<sub>WA</sub>, dB(A) at reference flow rate**

Supply inlet	61
Supply outlet	70
Exhaust inlet	61
Exhaust outlet	70
Casing	49

**A-weighted sound pressure level L<sub>PA</sub>, dB(A) 10 m<sup>2</sup> normally isolated room, distance from casing – 3 m.**

Surroundings	38
--------------	----

## Performance

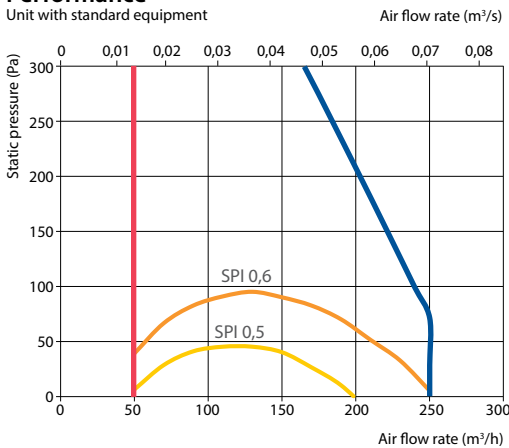

## Temperature efficiency

Outside temperature, °C	Winter					Summer		
	-23	-15	-10	-5	0	25	30	35
After heat exchanger, °C	10,7	12,7	14,0	15,2	16,5	22,8	24,0	25,3

indoor +22°C, 20 % RH

### Shown as right (R2)

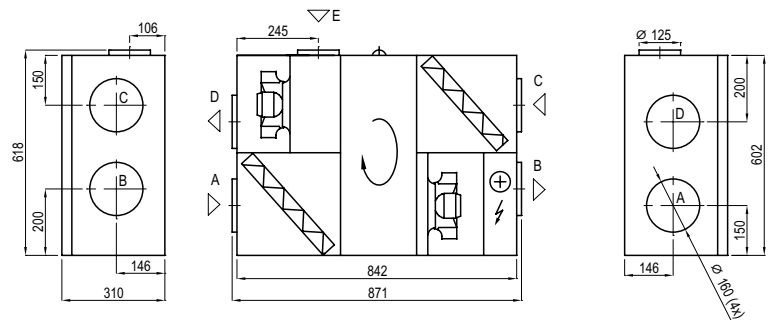

### Shown as left (L2)

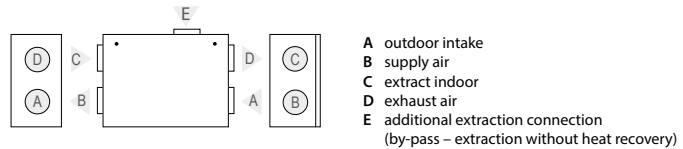

## Accessories (p. 108)

Closing damper	AGUJ-M-160+LF230/LM230
Silencer	A/D AGS-160-50-600-M B/C AGS-160-50-900-M
Water heater	DH-160

PPU	PPU-HW-3R-15-0,4-W1
2-way valve (water heater)	VVP47.10-0,4
Air heater-cooler	DHCW-160
2-way valve (water cooler)	VVP47.10-1,6