

# Service Manual

## Air Conditioner

**Indoor Unit**  
**CS-E18RD3EAW**

**Outdoor Unit**  
**CU-E18RBEA**

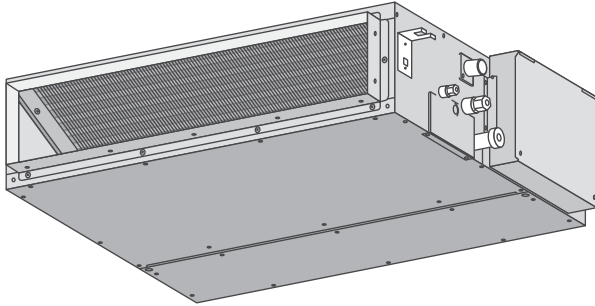

**Destination**  
**Europe**  
**Turkey**

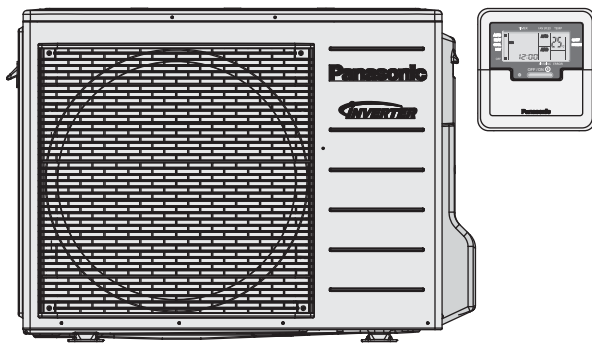

### **WARNING**

This service information is designed for experienced repair technicians only and is not designed for use by the general public. It does not contain warnings or cautions to advise non-technical individuals of potential dangers in attempting to service a product. Products powered by electricity should be serviced or repaired only by experienced professional technicians. Any attempt to service or repair the product or products dealt with in this service information by anyone else could result in serious injury or death.

### **IMPORTANT SAFETY NOTICE**

There are special components used in this equipment which are important for safety. These parts are marked by  in the Schematic Diagrams, Circuit Board Diagrams, Exploded Views and Replacement Parts List. It is essential that these critical parts should be replaced with manufacturer's specified parts to prevent shock, fire or other hazards. Do not modify the original design without permission of manufacturer.

### **PRECAUTION OF LOW TEMPERATURE**

In order to avoid frostbite, be assured of no refrigerant leakage during the installation or repairing of refrigerant circuit.



# Panasonic<sup>®</sup>

# TABLE OF CONTENTS

	PAGE		PAGE
<b>1. Safety Precautions</b> .....	<b>3</b>	15.5 Self-diagnosis Method .....	50
<b>2. Specifications</b> .....	<b>5</b>	<b>16. Disassembly and Assembly Instructions</b> .....	<b>74</b>
<b>3. Features</b> .....	<b>8</b>	16.1 Indoor Electronic Controller, Blower Fan, Fan Motor & Drain Motor Removal Procedure .....	74
<b>4. Location of Controls and Components</b> .....	<b>9</b>	16.2 Outdoor Electronic Controller Removal Procedure .....	77
4.1 Indoor Unit .....	9	<b>17. Technical Data</b> .....	<b>78</b>
4.2 Outdoor Unit .....	9	17.1 Cool Mode Performance Data .....	78
4.3 Remote Control .....	9	17.2 Heat Mode Performance Data .....	78
<b>5. Dimensions</b> .....	<b>10</b>	17.3 Fan Performance .....	79
5.1 Indoor Unit .....	10	<b>18. Service Data</b> .....	<b>80</b>
5.2 Outdoor Unit .....	11	18.1 Cool Mode Outdoor Air Temperature Characteristic .....	80
<b>6. Refrigeration Cycle Diagram</b> .....	<b>12</b>	18.2 Heat Mode Outdoor Air Temperature Characteristic .....	81
<b>7. Block Diagram</b> .....	<b>13</b>	18.3 Piping Length Correction Factor .....	82
<b>8. Wiring Connection Diagram</b> .....	<b>14</b>	<b>19. Exploded View and Replacement Parts List</b> .....	<b>83</b>
8.1 Indoor Unit .....	14	19.1 Indoor Unit .....	83
8.2 Outdoor Unit .....	15	19.2 Outdoor Unit .....	86
<b>9. Electronic Circuit Diagram</b> .....	<b>16</b>		
9.1 Indoor Unit .....	16		
9.2 Outdoor Unit .....	17		
<b>10. Printed Circuit Board</b> .....	<b>18</b>		
10.1 Indoor Unit .....	18		
10.2 Outdoor Unit .....	19		
<b>11. Installation Instruction</b> .....	<b>20</b>		
11.1 Indoor Unit .....	21		
11.2 Outdoor Unit .....	30		
<b>12. Operation and Control</b> .....	<b>34</b>		
12.1 Basic Function .....	34		
12.2 Quiet Operation (Cooling Mode/ Cooling Area of Soft Dry Mode) .....	37		
12.3 Powerful Mode Operation .....	38		
12.4 Timer Control .....	38		
12.5 Auto Restart Control .....	38		
12.6 Indication Panel .....	38		
<b>13. Protection Control</b> .....	<b>39</b>		
13.1 Protection Control For All Operations .....	39		
13.2 Protection Control For Cooling & Soft Dry Operation .....	40		
13.3 Protection Control For Heating Operation .....	42		
<b>14. Servicing Mode</b> .....	<b>44</b>		
14.1 TEST RUN OPERATION (FOR PUMP DOWN/SERVICING PURPOSE) .....	44		
<b>15. Troubleshooting Guide</b> .....	<b>45</b>		
15.1 Refrigeration Cycle System .....	45		
15.2 Relationship Between the Condition of the Air Conditioner and Pressure and Electric Current .....	46		
15.3 Breakdown Self Diagnosis Function .....	47		
15.4 Error Codes Table .....	48		

# 1. Safety Precautions





- Read the following “SAFETY PRECAUTIONS” carefully before perform any servicing.
- Electrical work must be installed or serviced by a licensed electrician. Be sure to use the correct rating of the power plug and main circuit for the model installed.
- The caution items stated here must be followed because these important contents are related to safety. The meaning of each indication used is as below. Incorrect installation or servicing due to ignoring of the instruction will cause harm or damage, and the seriousness is classified by the following indications.

 <b>WARNING</b>	This indication shows the possibility of causing death or serious injury.
 <b>CAUTION</b>	This indication shows the possibility of causing injury or damage to properties.

- The items to be followed are classified by the symbols:

	This symbol denotes item that is PROHIBITED from doing.
---	---







- Carry out test run to confirm that no abnormality occurs after the servicing. Then, explain to user the operation, care and maintenance as stated in instructions. Please remind the customer to keep the operating instructions for future reference.

 <b>WARNING</b>	
1. Do not modify the machine, part, material during repairing service.	
2. If wiring unit is supplied as repairing part, do not repair or connect the wire even only partial wire break. Exchange the whole wiring unit.	
3. Do not wrench the fasten terminal. Pull it out or insert it straightly.	
4. Engage dealer or specialist for installation and servicing. If installation of servicing done by the user is defective, it will cause water leakage, electrical shock or fire.	
5. Install according to this installation instructions strictly. If installation is defective, it will cause water leakage, electric shock or fire.	
6. Use the attached accessories parts and specified parts for installation and servicing. Otherwise, it will cause the set to fall, water leakage, fire or electrical shock.	
7. Install at a strong and firm location which is able to withstand the set's weight. If the strength is not enough or installation is not properly done, the set will drop and cause injury.	
8. For electrical work, follow the local national wiring standard, regulation and the installation instruction. An independent circuit and single outlet must be used. If electrical circuit capacity is not enough or defect found in electrical work, it will cause electrical shock or fire.	
9. This equipment is strongly recommended to be installed with Earth Leakage Circuit Breaker (ELCB) or Residual Current Device (RCD). Otherwise, it may cause electrical shock and fire in case equipment breakdown or insulation breakdown.	
10. Do not use joint cable for indoor / outdoor connection cable. Use the specified Indoor/Outdoor connection cable, refer to installation instruction CONNECT THE CABLE TO THE INDOOR UNIT and connect tightly for indoor / outdoor connection. Clamp the cable so that no external force will be acted on the terminal. If connecting or fixing is not perfect, it will cause heat up or fire at the connection.	
11. Wire routing must be properly arranged so that control board cover is fixed properly. If control board cover is not fixed perfectly, it will cause heat-up or fire at the connection point of terminal, fire or electrical shock.	
12. When install or relocate air conditioner, do not let any substance other than the specified refrigerant, eg. air etc. mix into refrigeration cycle (piping). (Mixing of air etc. will cause abnormal high pressure in refrigeration cycle and result in explosion, injury etc.).	
13. Do not install outdoor unit near handrail of veranda. When installing air-conditioner unit at veranda of high rise building, child may climb up to outdoor unit and cross over the handrail and causing accident.	
14. This equipment must be properly earthed. Earth line must not be connected to gas pipe, water pipe, earth of lightning rod and telephone. Otherwise, it may cause electrical shock in case equipment breakdown or insulation breakdown.	
15. Keep away from small children, the thin film may cling to nose and mouth and prevent breathing.	
16. Do not use unspecified cord, modified cord, joint cord or extension cord for power supply cord. Do not share the single outlet with other electrical appliances. Poor contact, poor insulation or over current will cause electrical shock or fire.	
17. Tighten the flare nut with torque wrench according to specified method. If the flare nut is over-tightened, after a long period, the flare may break and cause refrigerant gas leakage.	
18. For R410A model, use piping, flare nut and tools which is specified for R410A refrigerant. Using of existing (R22) piping, flare nut and tools may cause abnormally high pressure in the refrigerant cycle (piping), and possibly result in explosion and injury. Thickness of copper pipes used with R410A must be more than 0.8 mm. Never use copper pipes thinner than 0.8 mm. It is desirable that the amount of residual oil less than 40 mg/10 m.	

 **WARNING**

- |   |   |
|---|---|
| 19. During installation, install the refrigerant piping properly before run the compressor. (Operation of compressor without fixing refrigeration piping and valves at opened condition will cause suck-in of air, abnormal high pressure in refrigeration cycle and result in explosion, injury etc).    |   |
| 20. During pump down operation, stop the compressor before remove the refrigeration piping. (Removal of refrigeration piping while compressor is operating and valves are opened condition will cause suck-in of air, abnormal high pressure in refrigeration cycle and result in explosion, injury etc.) |   |
| 21. After completion of the installation servicing, confirm there is no leakage or refrigerant gas. It may generate toxic gas when the refrigerant contacts with fire.  |   |
| 22. Ventilate if there is refrigerant gas leakage during operation. It may cause toxic gas when the refrigerant contacts with fire.   |   |
| 23. Do not insert your fingers or other objects into the unit, high speed rotating fan may cause injury.  |  |
| 24. Must not use other parts except original parts describe in catalog and manual.  |   |

 **CAUTION**

- |  |   |
|--|---|
| 1. Do not install the unit at place where leakage of flammable gas may occur. In case gas leaks and accumulates at surrounding of the unit, it may cause fire.   |    |
| 2. Carry out drainage piping as mentioned in installation instructions. If drainage is not perfect, water may enter the room and damage the furniture.   |   |
| 3. Tighten the flare nut with torque wrench according to specified method. If the flare nut is over-tightened, after a long period, the flare may break and cause refrigerant gas leakage.   |   |
| 4. Do not touch outdoor unit air inlet and aluminium fin. It may cause injury.   |    |
| 5. Select an installation location which is easy for maintenance.  |   |
| 6. Pb free solder has a higher melting point than standard solder; typically the melting point is 50°F – 70°F (30°C – 40°C) higher. Please use a high temperature solder iron. In case of the soldering iron with temperature control, please set it to 700 ± 20°F (370 ± 10°C). Pb free solder will tend to splash when heated too high (about 1100°F / 600°C).   |   |
| 7. Power supply connection to the room air conditioner.<br>Use power supply cord 3 x 2.5 mm <sup>2</sup> type designation 60245 IEC 57 or heavier cord.<br>Connect the power supply cord of the air conditioner to the mains using one of the following method.<br>Power supply point should be in easily accessible place for power disconnection in case of emergency.<br>In some countries, permanent connection of this air conditioner to the power supply is prohibited.<br>1. Power supply connection to the receptacle using power plug.<br>Use an approved 16A power plug with earth pin for the connection to the socket.<br>2. Power supply connection to a circuit breaker for the permanent connection.<br>Use an approved 16A circuit breaker for the permanent connection. It must be a double pole switch with a minimum 3.0 mm contact gap. |   |
| 8. Do not release refrigerant during piping work for installation, servicing, reinstallation and during repairing a refrigerant parts.<br>Take care of the liquid refrigerant, it may cause frostbite.   |  |
| 9. Installation or servicing work: It may need two people to carry out the installation or servicing work.   |   |
| 10. Do not install this appliance in a laundry room or other location where water may drip from the ceiling, etc.  |  |
| 11. Do not sit or step on the unit, you may fall down accidentally.  |  |
| 12. Do not touch the sharp aluminium fin, sharp parts may cause injury.<br>If you are required to handle sharp parts during installation or servicing, please wear hand glove.<br>Sharp parts may cause injury.  |  |

## 2. Specifications

MODEL		INDOOR	CS-E18RD3EAW							
		OUTDOOR	CU-E18RBEA							
Performance Test Condition		EUROVENT								
Power Supply		Phase, Hz	Single, 50							
		V	220			230				
			Min.	Mid.	Max.	Min.	Mid.	Max.		
Cooling	Capacity	kW	0.90	5.10	5.70	0.90	5.10	5.70		
		BTU/h	3070	17400	19400	3070	17400	19400		
		kcal/h	770	4390	4900	770	4390	4900		
	Running Current	A	-	7.60	-	-	7.30	-		
	Input Power	W	255	1.60k	1.82k	255	1.60k	1.82k		
	Annual Consumption	kWh	-	800	-	-	800	-		
	EER	W/W	3.53	3.19	3.13	3.53	3.19	3.13		
		BTU/hW	12.04	10.88	10.66	12.04	10.88	10.66		
		kcal/hW	3.02	2.74	2.69	3.02	2.74	2.69		
	ErP	Pdesign	kW	5.1						
		SEER	W/W	5.8						
		Annual Consumption	kWh	308						
		Class		A+						
	Power Factor	%	-	96	-	-	95	-		
	Indoor Noise (H / L / QLo)	dB-A	41 / 30 / 27			41 / 30 / 27				
		Power Level dB	57 / 46 / 43			57 / 46 / 43				
	Outdoor Noise (H / L / QLo)	dB-A	47 / - / -			47 / - / -				
		Power Level dB	61 / - / -			61 / - / -				
Heating	Capacity	kW	0.90	6.10	7.10	0.90	6.10	7.10		
		BTU/h	3070	20800	24200	3070	20800	24200		
		kcal/h	770	5250	6110	770	5250	6110		
	Running Current	A	-	8.60	-	-	8.30	-		
	Input Power	W	260	1.83k	2.18k	260	1.83k	2.18k		
	COP	W/W	3.46	3.33	3.26	3.46	3.33	3.26		
		BTU/hW	11.81	11.37	11.10	11.81	11.37	11.10		
		kcal/hW	2.96	2.87	2.80	2.96	2.87	2.80		
	ErP	Pdesign	kW	4.0						
		Tbivalent	°C	-10						
		SCOP	W/W	3.9						
		Annual Consumption	kWh	1436						
		Class		A						
	Power Factor	%	-	97	-	-	96	-		
	Indoor Noise (H / L / QLo)	dB-A	41 / 32 / 29			41 / 32 / 29				
		Power Level dB	57 / 48 / 45			57 / 48 / 45				
	Outdoor Noise (H / L / QLo)	dB-A	48 / - / -			48 / - / -				
		Power Level dB	62 / - / -			62 / - / -				
※3 Low Temp. : Capacity (kW) / I. Power (W) / COP		5.14 / 1.93k / 2.66								
※4 Extr Low Temp. : Capacity (kW) / I. Power (W) / COP		4.30 / 1.88k / 2.29								
Max Current (A) / Max Input Power (W)		10.2 / 2.18k								
Starting Current (A)		8.60								

MODEL		INDOOR		CS-E18RD3EAW		
		OUTDOOR		CU-E18RBEA		
Compressor	Type			Hermetic Motor / Rotary		
	Motor Type			Brushless (4-poles)		
	Output Power			900		
Indoor Fan	Type			Sirocco		
	Material			GFZ010A / GF20		
	Motor Type			DC Motor (8-poles)		
	Output Power		W	51		
	Speed	QLo	Cool	rpm	920	
			Heat	rpm	920	
		Lo	Cool	rpm	980	
			Heat	rpm	1000	
		Me	Cool	rpm	1230	
			Heat	rpm	1240	
		Hi	Cool	rpm	1480	
			Heat	rpm	1480	
SHi	Cool	rpm	1530			
	Heat	rpm	1530			
Outdoor Fan	Type			Propeller Fan		
	Material			PP		
	Motor Type			DC Motor (8-poles)		
	Output Power		W	40		
	Speed	Hi	Cool	rpm	640	
Heat			rpm	640		
Moisture Removal		L/h (Pt/h)	2.8 (5.9)			
Indoor Airflow	QLo	Cool	m <sup>3</sup> /min (ft <sup>3</sup> /min)	8.8 (311)		
		Heat	m <sup>3</sup> /min (ft <sup>3</sup> /min)	8.8 (311)		
	Lo	Cool	m <sup>3</sup> /min (ft <sup>3</sup> /min)	9.4 (332)		
		Heat	m <sup>3</sup> /min (ft <sup>3</sup> /min)	9.8 (346)		
	Me	Cool	m <sup>3</sup> /min (ft <sup>3</sup> /min)	12.6 (445)		
		Heat	m <sup>3</sup> /min (ft <sup>3</sup> /min)	12.6 (445)		
	Hi	Cool	m <sup>3</sup> /min (ft <sup>3</sup> /min)	15.3 (540)		
		Heat	m <sup>3</sup> /min (ft <sup>3</sup> /min)	15.3 (540)		
SHi	Cool	m <sup>3</sup> /min (ft <sup>3</sup> /min)	16.0 (565)			
	Heat	m <sup>3</sup> /min (ft <sup>3</sup> /min)	16.0 (565)			
Outdoor Airflow	Hi	Cool	m <sup>3</sup> /min (ft <sup>3</sup> /min)	39.2 (1385)		
		Heat	m <sup>3</sup> /min (ft <sup>3</sup> /min)	39.2 (1385)		
Refrigeration Cycle	Control Device			Expansion Valve		
	Refrigerant Oil		cm <sup>3</sup>	FV50S (450)		
	Refrigerant Type		g (oz)	R410A, 1.23k (43.4)		
Dimension	Height (I/D / O/D)		mm (inch)	200 (7-7/8) / 695 (27-3/8)		
	Width (I/D / O/D)		mm (inch)	750 (29-17/32) / 875 (34-15/32)		
	Depth (I/D / O/D)		mm (inch)	640 (25-7/32) / 320 (12-5/8)		
Weight	Net (I/D / O/D)		kg (lb)	19 (42) / 47 (104)		

MODEL		INDOOR	CS-E18RD3EAW	
		OUTDOOR	CU-E18RBEA	
Piping	Pipe Diameter (Liquid / Gas)	mm (inch)	6.35 (1/4) / 12.70 (1/2)	
	Standard Length	m (ft)	5.0 (16.4)	
	Length Range (min - max)	m (ft)	3 (9.8) ~ 30 (98.4)	
	I/D & O/D Height Different	m (ft)	20 (65.6)	
	Additional Gas Amount	g/m (oz/ft)	20 (0.2)	
	Length for Additional Gas	m (ft)	10 (32.8)	
Drain Hose	Inner Diameter	mm	19.5	
	Length	mm	131	
Indoor Heat Exchanger	Fin Material		Aluminium (Pre Coat)	
	Fin Type		Slit Fin	
	Row x Stage x FPI		3 x 12 x 18	
	Size (W x H x L)	mm	590 x 282 x 38.1	
Outdoor Heat Exchanger	Fin Material		Aluminium (Pre Coat)	
	Fin Type		Corrugated Fin	
	Row x Stage x FPI		2 x 31 x 19	
	Size (W x H x L)	mm	36.4 x 651 x 854.5:824.5	
Power Supply			Outdoor Power Supply	
Power Supply Cord		A	Nil	
Thermostat			Electronic Control	
Protection Device			Electronic Control	
			Dry Bulb	Wet Bulb
Indoor Operation Range	Cooling	Maximum °C	32	23
		Minimum °C	16	11
	Heating	Maximum °C	30	-
		Minimum °C	16	-
Outdoor Operation Range	Cooling	Maximum °C	43	26
		Minimum °C	-10	-
	Heating	Maximum °C	24	18
		Minimum °C	-10	-

- Cooling capacities are based on indoor temperature of 27°C Dry Bulb (80.6°F Dry Bulb), 19.0°C Wet Bulb (66.2°F Wet Bulb) and outdoor air temperature of 35°C Dry Bulb (95°F Dry Bulb), 24°C Wet Bulb (75.2°F Wet Bulb)
- Heating capacities are based on indoor temperature of 20°C Dry Bulb (68°F Dry Bulb) and outdoor air temperature of 7°C Dry Bulb (44.6°F Dry Bulb), 6°C Wet Bulb (42.8°F Wet Bulb)
- ×3 Heating low temperature capacity, Input Power and COP measured at 230 V, indoor temperature 20°C, outdoor 2/1°C
- ×4 Heating extreme low temperature capacity, Input Power and COP measured at 230 V indoor temperature 20°C, outdoor -7/-8°C
- Standby power consumption ≤0.7W (when switched OFF by remote control, except under self protection control).
- Specifications are subjected to change without notice for further improvement.

### 3. Features

- **Inverter Technology**
  - Wider output power range
  - Energy saving
  - Quick Cooling
  - Quick Heating
  - More precise temperature control
- **Environment Protection**
  - Non-ozone depletion substances refrigerant (R410A)
- **Long Installation Piping**
  - Long piping up to 30 meter
- **Easy to use remote control**
- **Quality Improvement**
  - Random auto restart after power failure for safety restart operation
  - Gas leakage protection
  - Prevent compressor reverse cycle
  - Inner protector to protect compressor
  - Noise prevention during soft dry operation
- **Operation Improvement**
  - Quiet mode to reduce the indoor unit operating sound
  - Powerful mode to reach the desired room temperature quickly
  - 24-hour timer setting
- **Serviceability Improvement**
  - Breakdown Self Diagnosis function



## 4. Location of Controls and Components

### 4.1 Indoor Unit

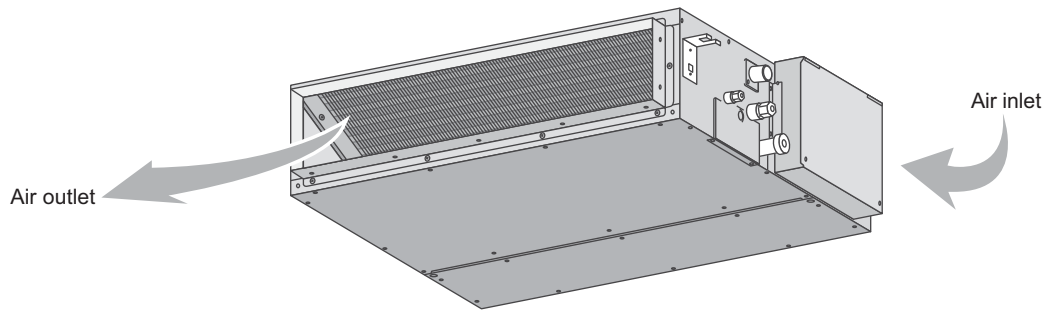

### 4.2 Outdoor Unit

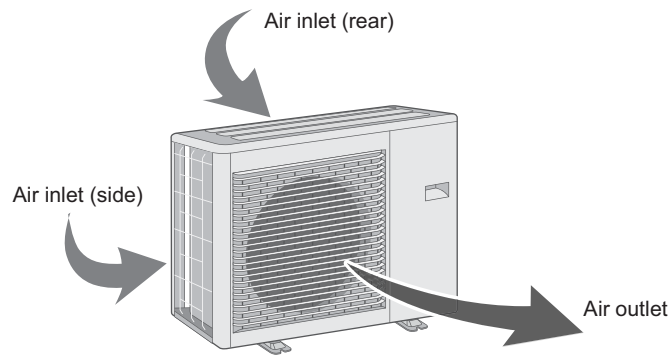

### 4.3 Remote Control

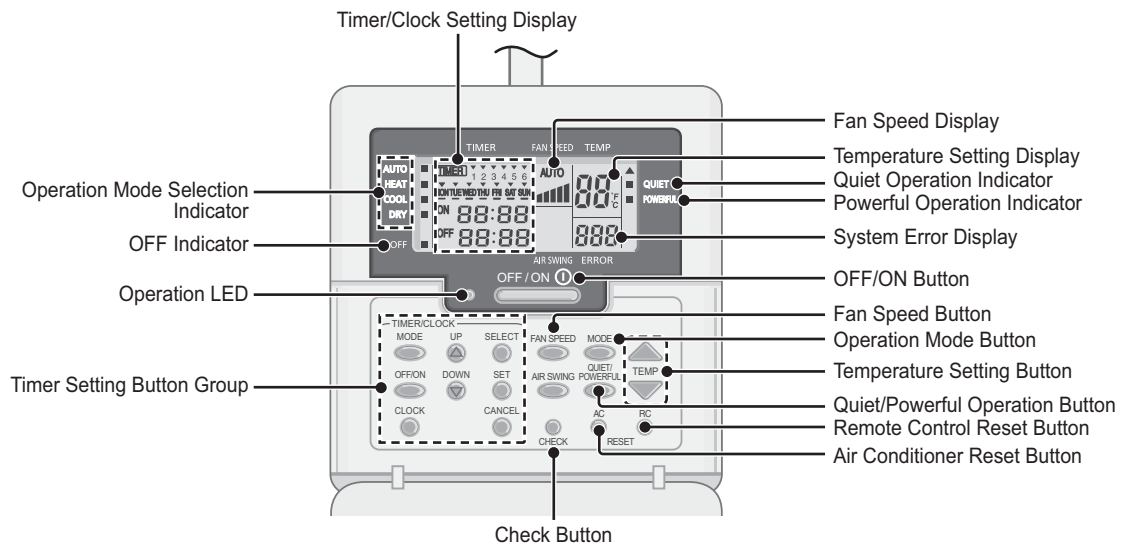

# 5. Dimensions

## 5.1 Indoor Unit

<Front View>

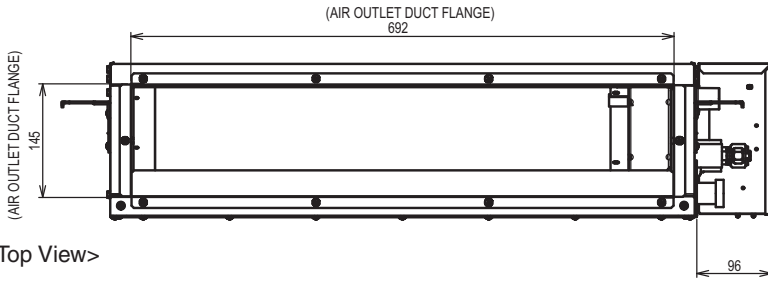

<Top View>

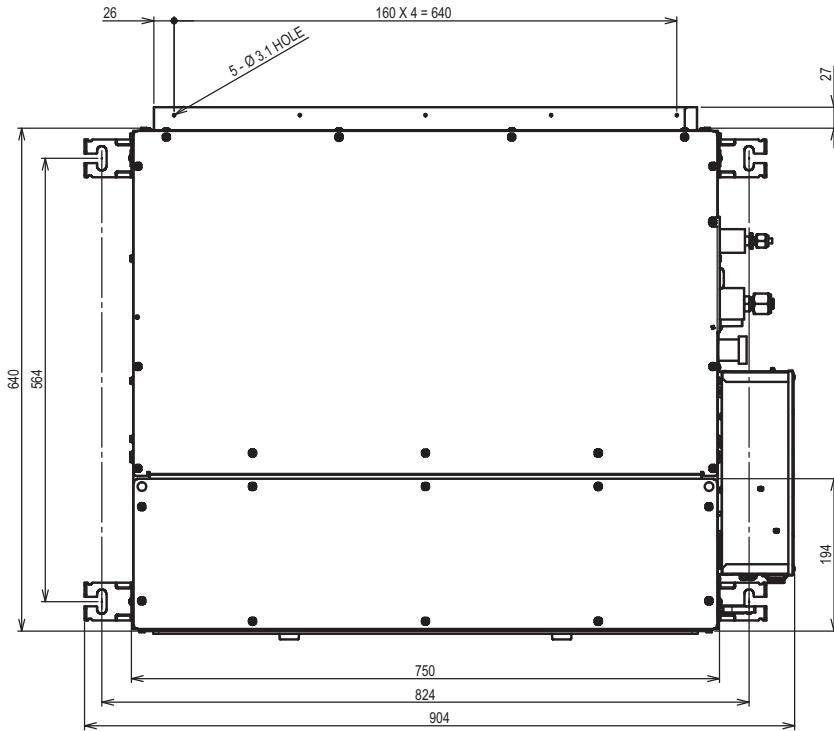

<Side View>

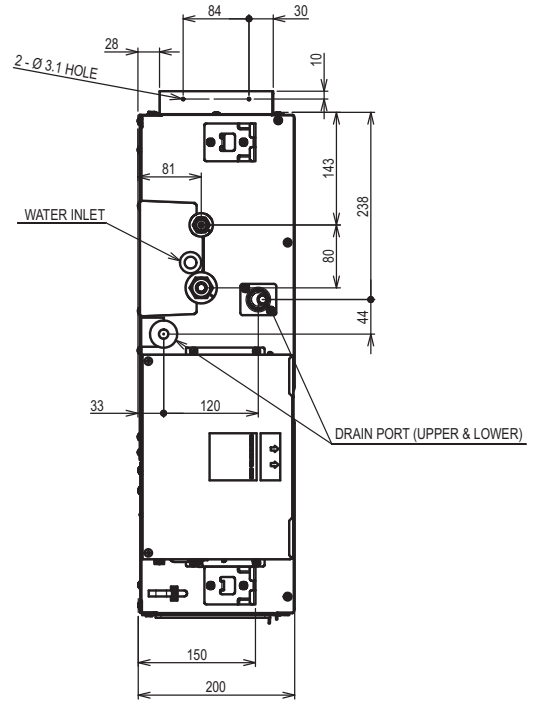

<Back View>

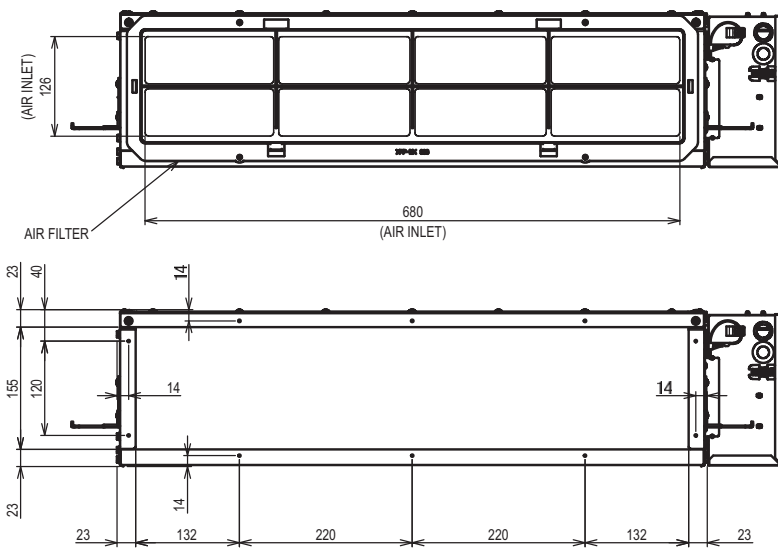

<Remote Control>

Remote control transmitter

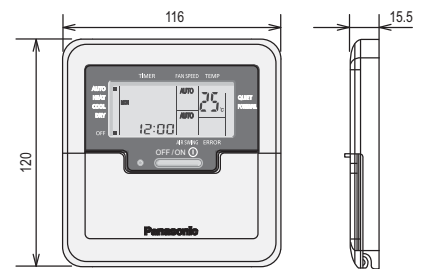

Unit : mm

## 5.2 Outdoor Unit

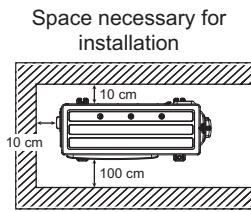

Anchor Bolt Pitch  
360.5 x 613

<Side View>

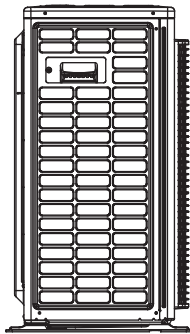

Unit: mm

<Top View>

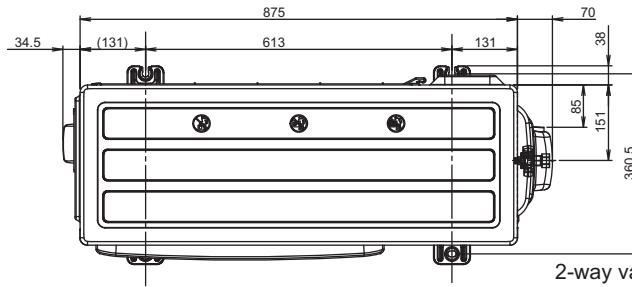

2-way valve at Liquid side  
(High Pressure)

3-way valve at Gas side  
(Low Pressure)

<Front View>

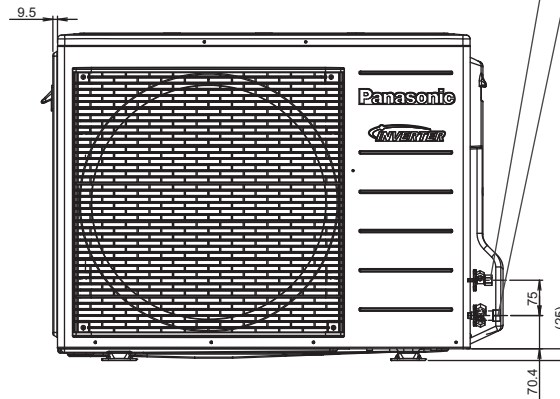

<Side View>

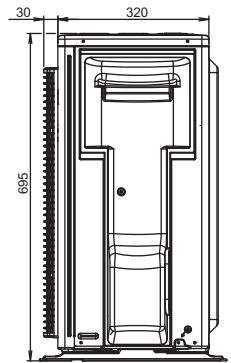

# 6. Refrigeration Cycle Diagram

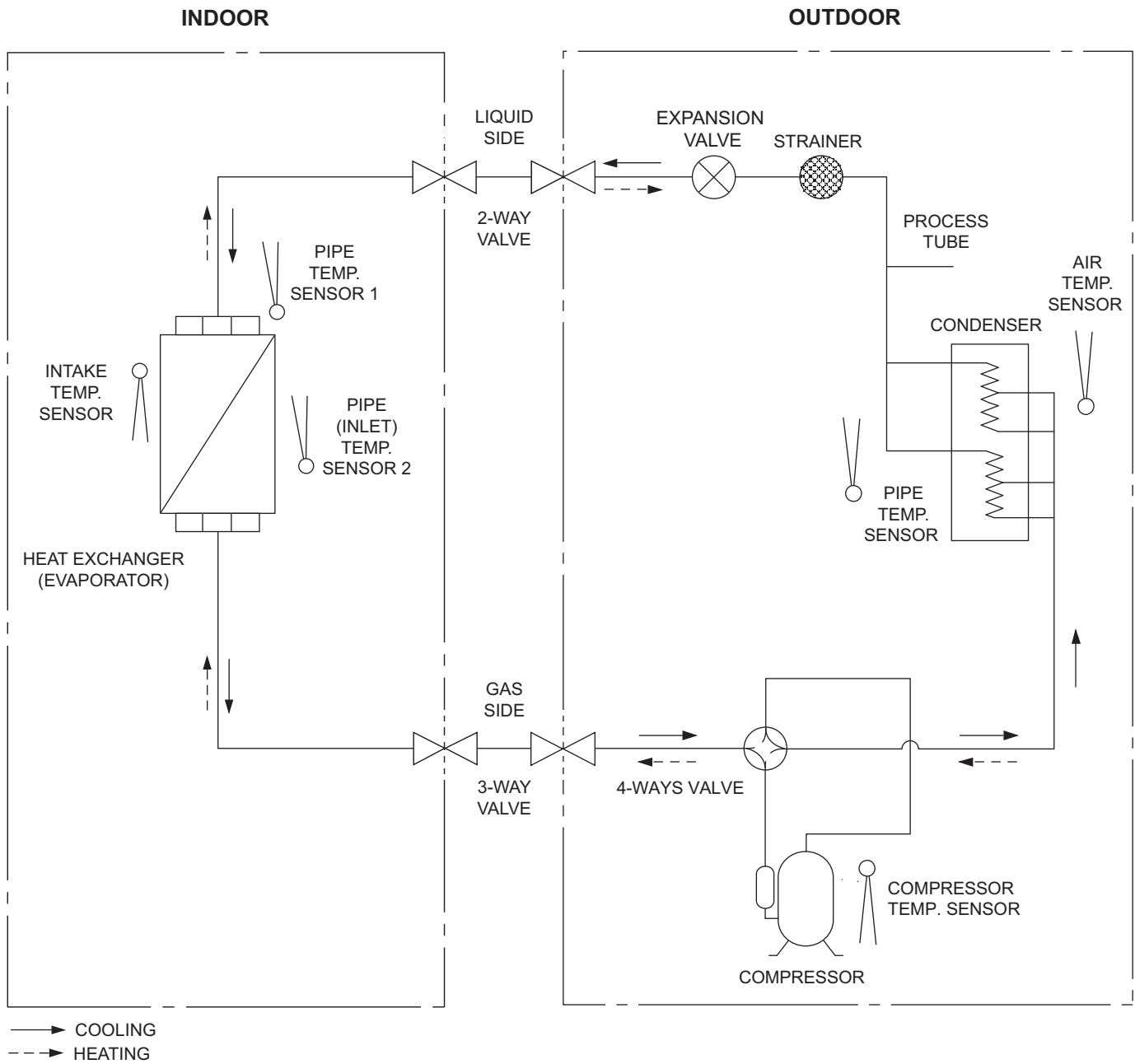

# 7. Block Diagram

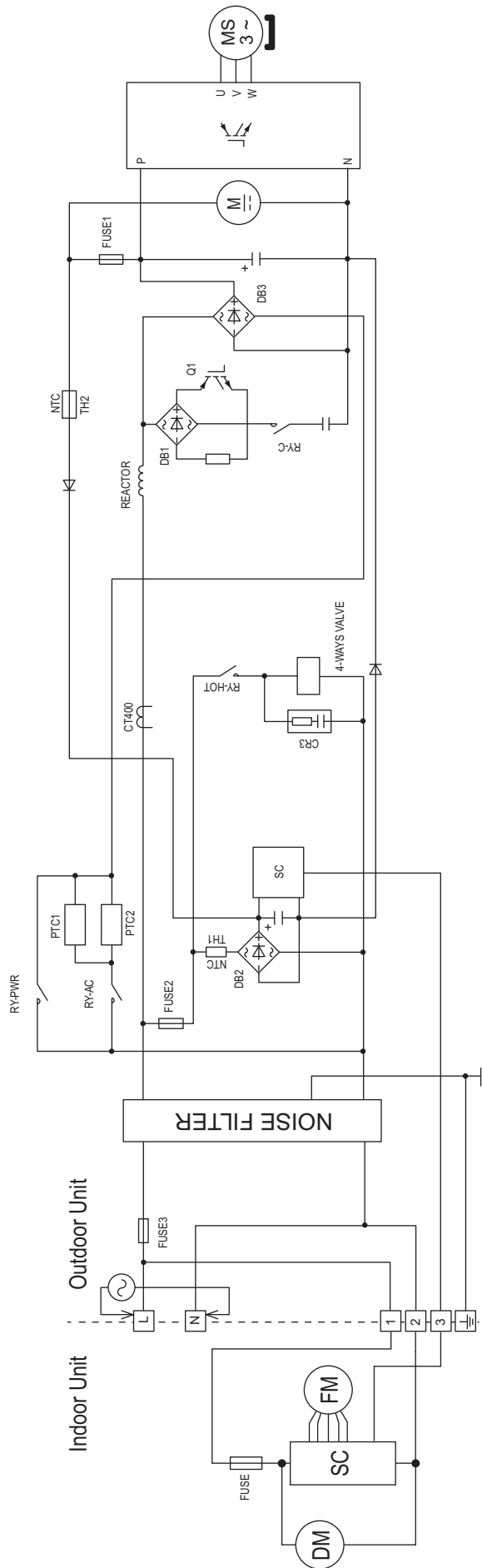

# 8. Wiring Connection Diagram

## 8.1 Indoor Unit

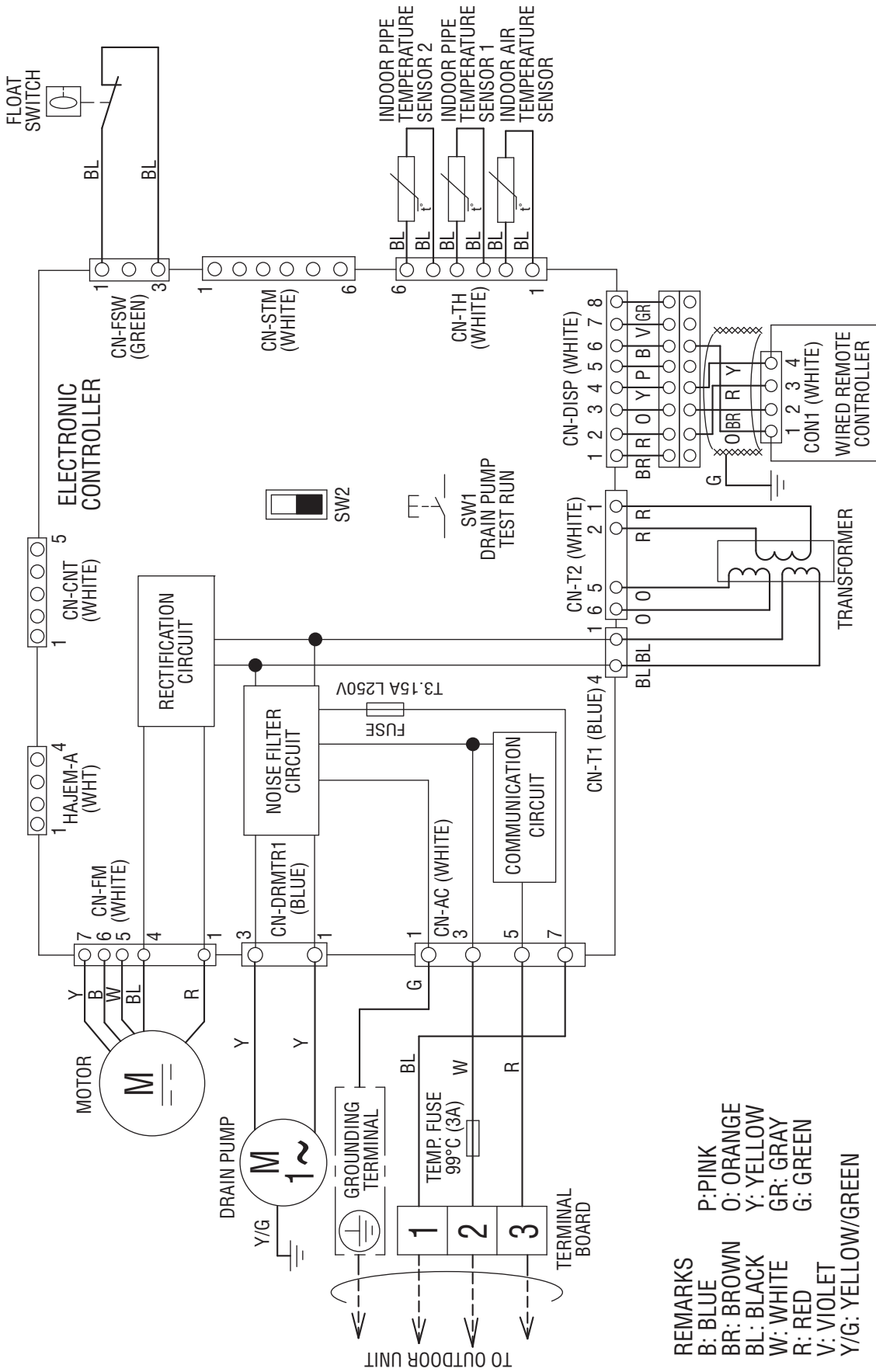

## 8.2 Outdoor Unit

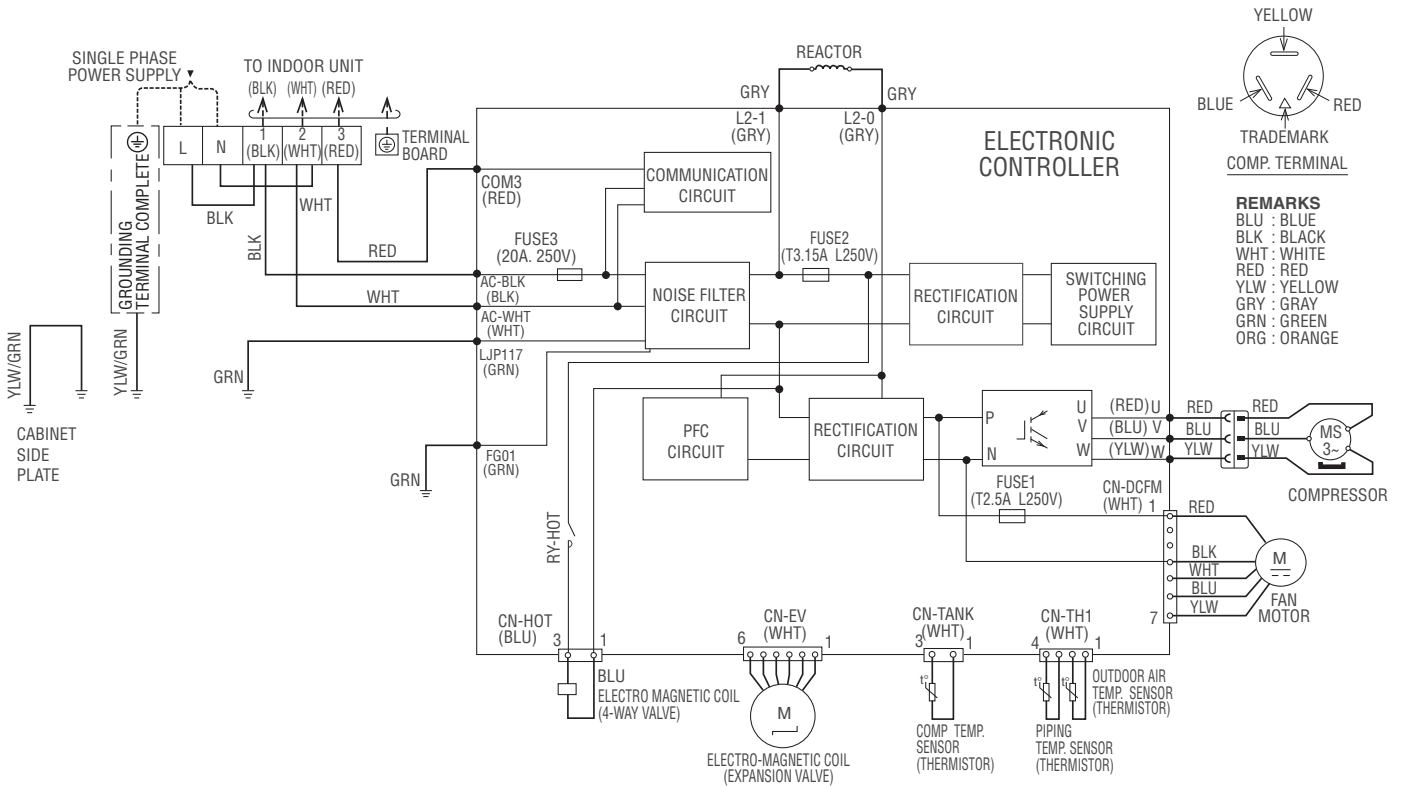

Resistance of Compressor Windings

MODEL	CU-E18RBEA
CONNECTION	5RD132XBA21
U-V	1.897 Ω
U-W	1.907 Ω
V-W	1.882 Ω

Note: Resistance at 20°C of ambient temperature.

# 9. Electronic Circuit Diagram

## 9.1 Indoor Unit

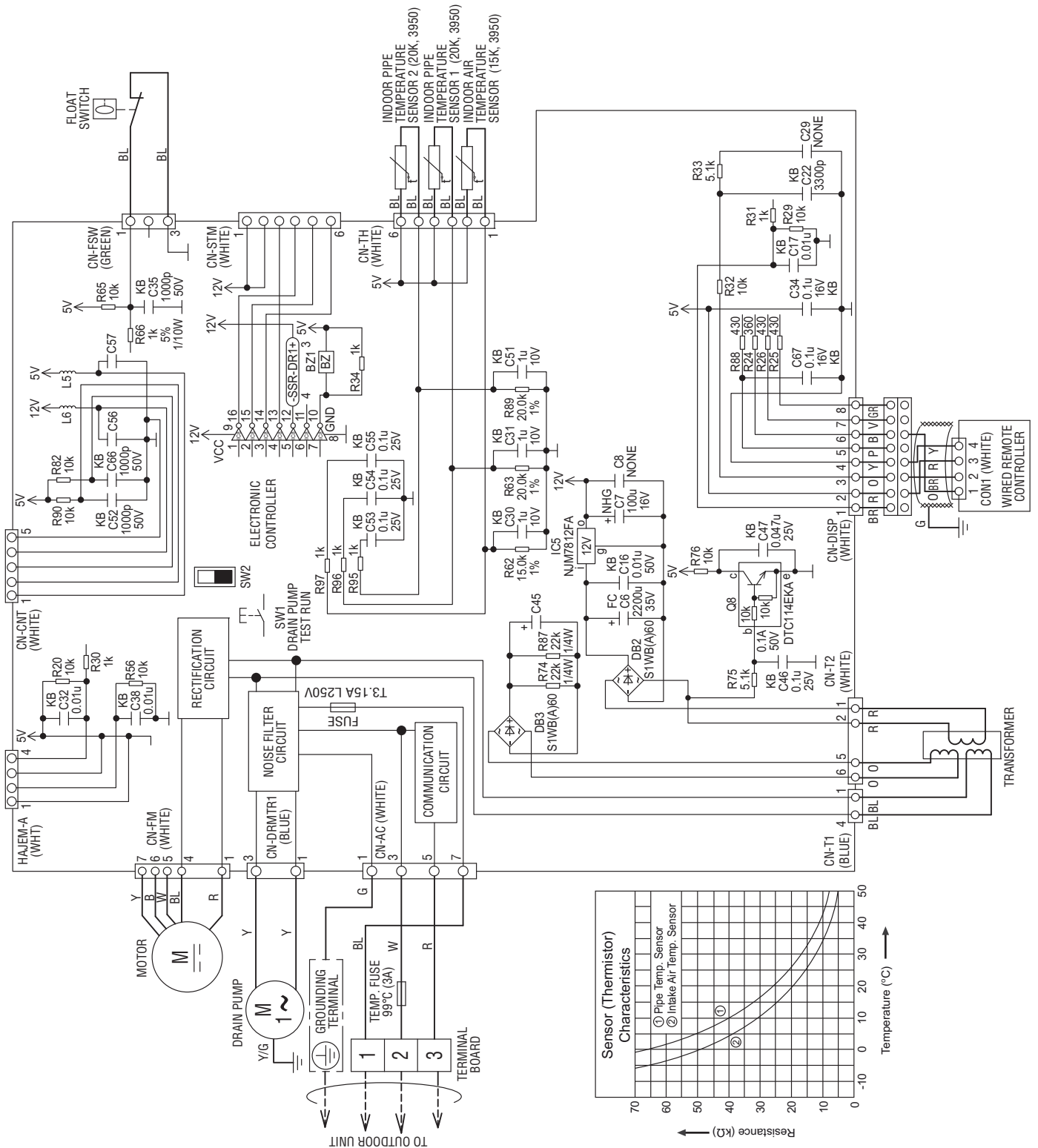





# 10. Printed Circuit Board

## 10.1 Indoor Unit

### 10.1.1 Main Printed Circuit Board

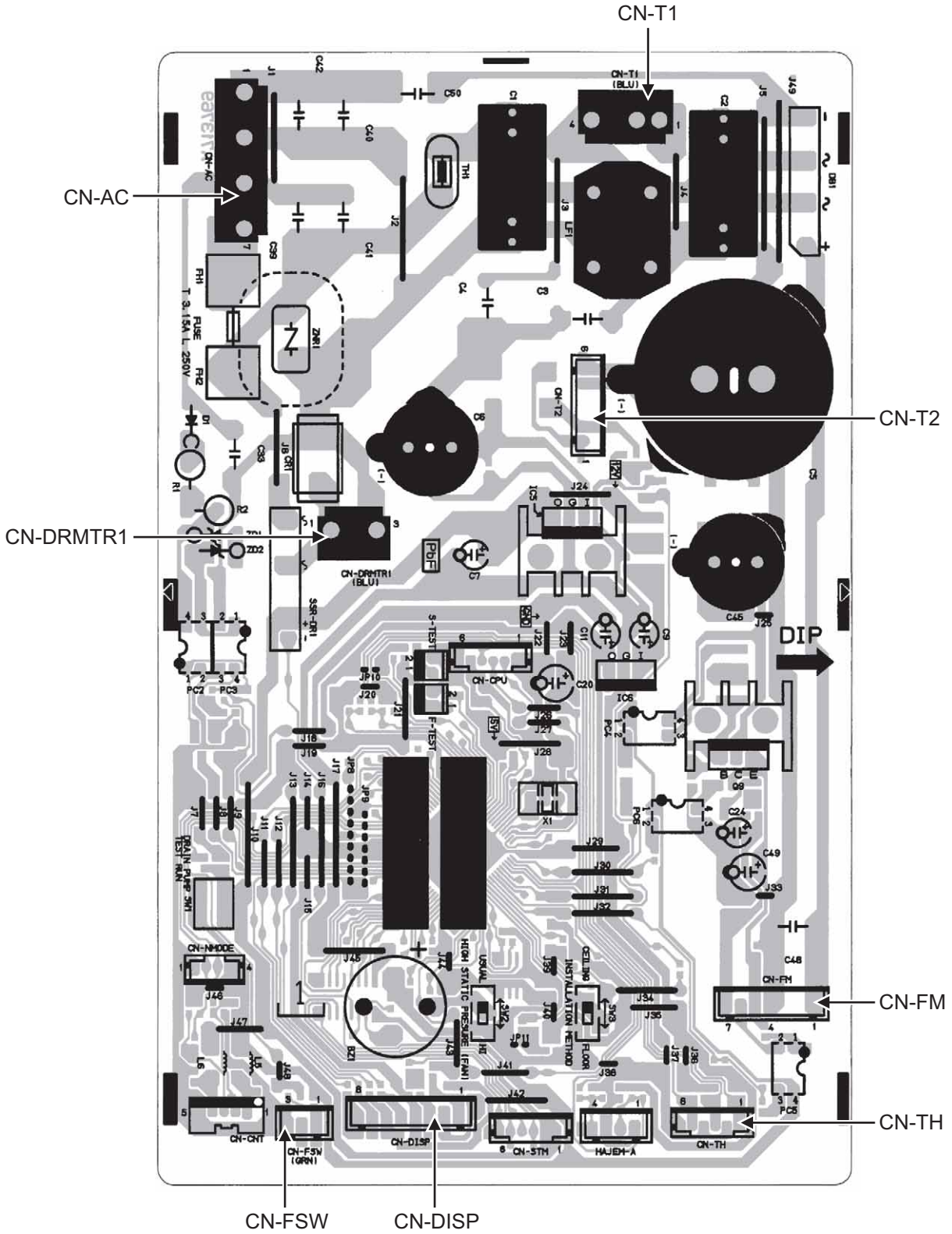



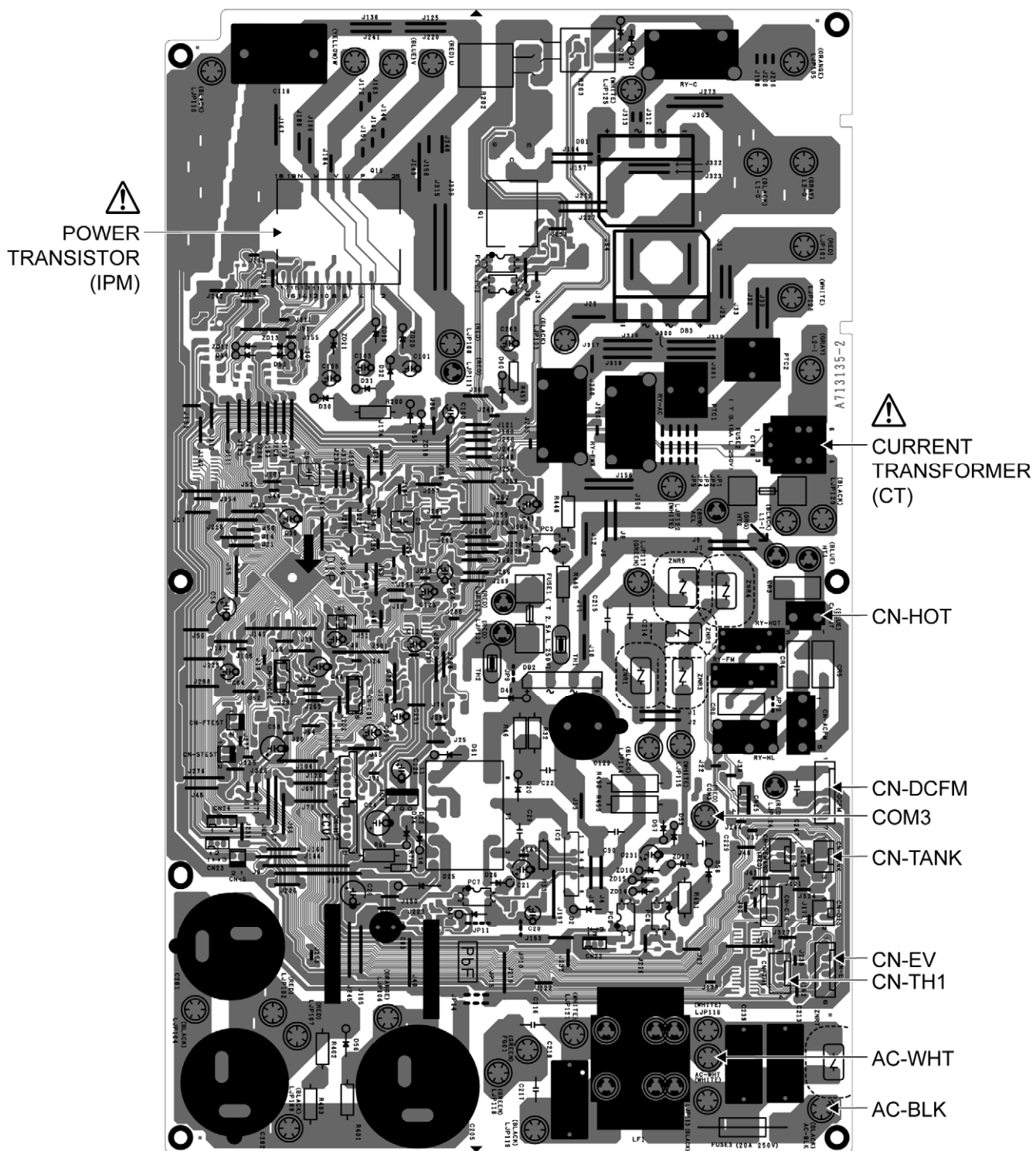

## 10.2 Outdoor Unit





### 10.2.1 Main Printed Circuit Board







# 11. Installation Instruction

## Attached accessories

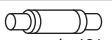
No.	Accessory part	Qty.
1	Remote controller 	1
2	Remote controller cable 	1
3	Screw (M4 machine pitched - 30 mm) 	3
4	Screw (M4 self tapping - 14 mm) 	3

No.	Accessory part	Qty.
5	Drain elbow 	1
6	Washer (for suspension fitting) 	8
7	Flare insulator (for gas pipe / liquid pipe connection) 	2
8	Clamper (band) (for flare & drain insulating connection) 	4

No.	Accessory part	Qty.
9	Drain Hose (for unit & PVC pipe connection)  L=131	1
10	Hose Band (for drain hose connection) 	1
11	Drain Hose insulation (for drain pipe connection) 	2
12	Clamper (Band) (for power supply cord)  * Be sure to fix the power supply cord with clamper (band).	1

### Required Materials

- Read the catalog and other technical materials and prepare the required materials.
- Applicable piping kit

Applicable piping kit	Piping size	
	Gas	Liquid
CZ-3F5, 7BP	9.52 mm (3/8")	6.35 mm (1/4")
CZ-4F5, 7, 10BP	12.7 mm (1/2")	6.35 mm (1/4")
CZ-52F5, 7, 10BP	15.88 mm (5/8")	6.35 mm (1/4")

- Pipe Size Reducer (CZ-MA1P) for Outdoor Multi connection
- Please refer to "11.2.3 connect the piping" in outdoor unit section

### Other Items to be Prepared (Locally Purchased)

Product name	Remarks
Rigid PVC pipe	VP20 (outer diameter ø26); also sockets, elbows and other parts as necessary
Adhesive	PVC adhesive
Insulation	For refrigerant piping insulation : foamed polyethylene with a thickness of 8 mm or more. For drain piping insulation : foamed polyethylene with a thickness of 10 mm or more.
Indoor/outdoor connecting cable	4 x 1.5 mm <sup>2</sup> flexible cord, designation type 60245 IEC 57 (H05RN-F)
Hanging bolt related parts	Hanging bolts (M10) (4) and nuts (12), (when hanging the indoor unit)

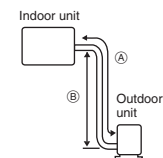
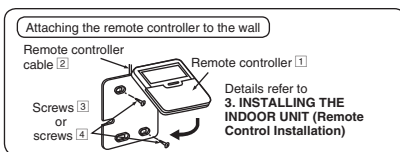
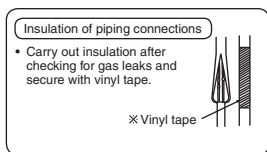

**IMPORTANT**  
Begin the installation job from the "Indoor Unit" installation.

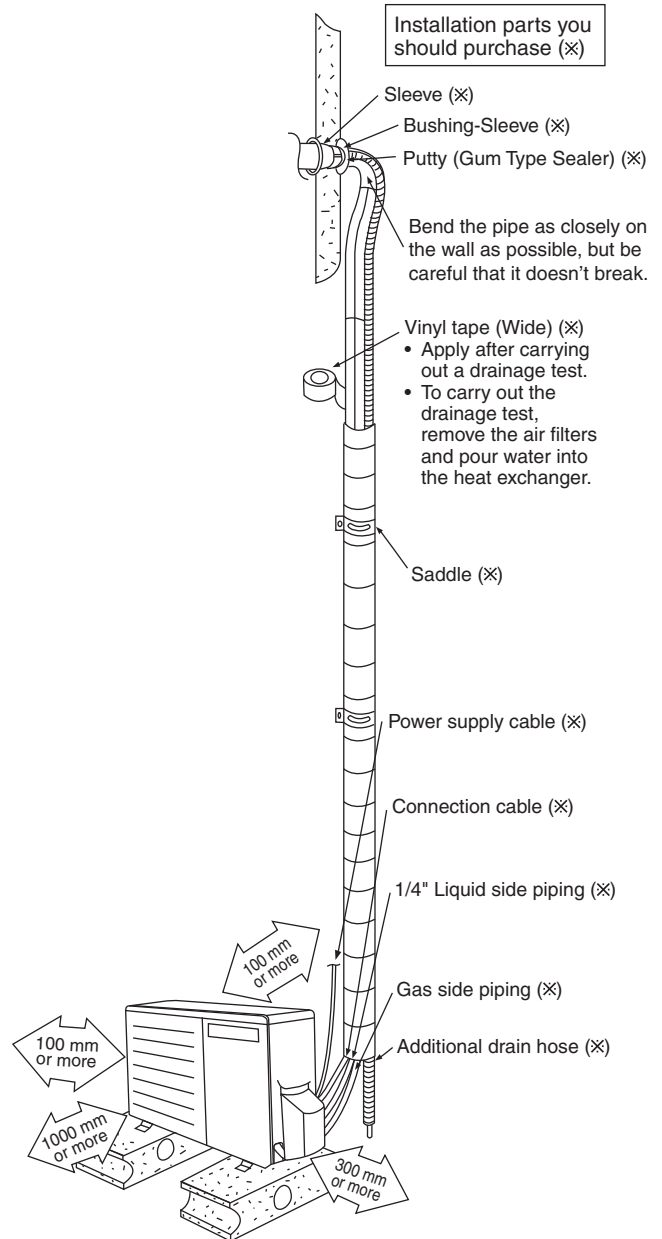

It is advisable to avoid more than 2 blockage directions. For better ventilation & multiple-outdoor installation, please consult authorized dealer/specialist.

Or

- This illustration is for explanation purposes only. The indoor unit will actually face a different way.

## 11.1 Indoor Unit

### 11.1.1 Selecting the Installation Location

Take into consideration the following contents when creating the blueprint.

#### ■ Indoor unit installation location

- Do not install the unit in excessive oil fume area such as kitchen, workshop and etc.
- The location should be strong enough to support the main unit without vibration.
- There should not be any heat or steam source nearby.
- Drainage should be easy. Avoid locating the drain port close to ditches (domestic wastewater).
- Avoid locations above entrances and exits.
- Do not block the air intake and discharge passages.
- Select the location that enables the cool and warm air to spread out to the entire room.
- Locate the indoor unit at least 1 m or more away from a TV, radio, wireless appliance, antenna cable and fluorescent light, and 2 m or more away from a telephone.
- Recommended installation height for indoor unit shall be at least 2.5 m from floor.

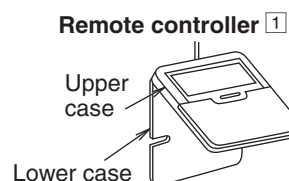
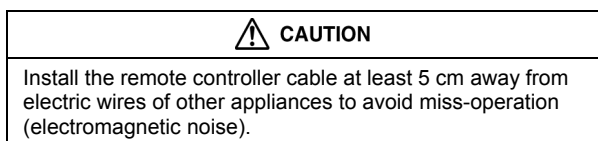

#### ■ Remote control mounting location

- Allow sufficient space around the remote controller **1** as shown in the illustration at right.
- Install in a place which is away from direct sunlight and high humidity.
- Install in a flat surface to avoid warping of the remote controller. If installed to a wall with an uneven surface, damage to the LCD case or operation problems may result.
- Install in a place where the LCD can be easily seen for operation.  
(Standard height from the floor is 1.2 to 1.5 meters.)
- Avoid installing the remote controller cable near refrigerant pipes or drain pipes, else it will cause electrical shock or fire.

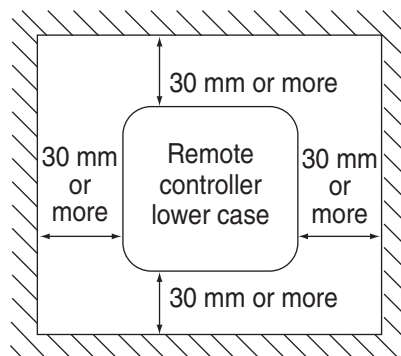

### 11.1.2 To Drill a Hole in the Wall and Install a Sleeve of Piping

- 1 Insert the piping sleeve to the hole.
- 2 Fix the bushing to the sleeve.
- 3 Cut the sleeve until it extrudes about 15 mm from the wall.

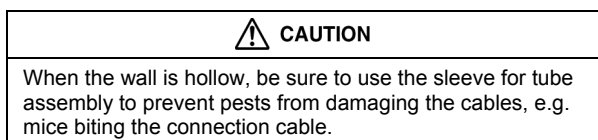

- 4 Finish by sealing the sleeve with putty or caulking compound at the final stage.

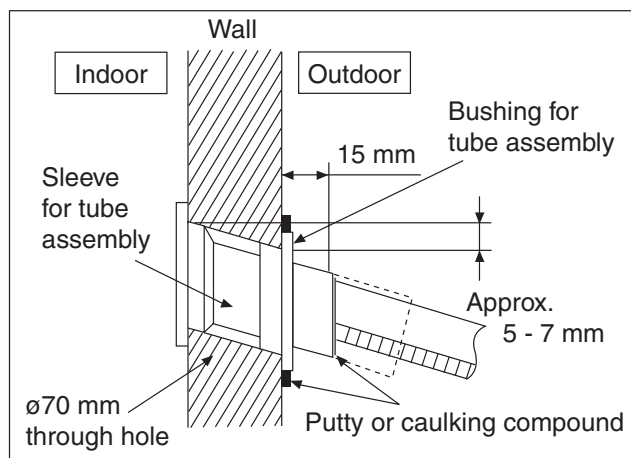

### 11.1.3 Installing the Indoor Unit (Installation Embedded in the Ceiling)

#### 11.1.3.1 Preparation Before Installation

- Always provide sufficient entry and exit space to allow installation work, inspection and unit replacement.
- Waterproof the rear surface of the ceiling below the unit in consideration of water droplets forming and dropping.

#### ⚠ CAUTION

When cooling operation is performed for an extended period under the following conditions, water droplets may form and drop. Attach locally purchased insulation (foamed polyethylene with a thickness of 5 mm or more) to the outside of the indoor unit before installing into the ceiling to improve heat insulation.

- Locations with a dew point inside the ceiling of 23°C or more
  - Kitchens and other locations that produce large amounts of heat and steam
  - Locations where the inside of the ceiling serves as an outside air intake passage
- **When installing into a ceiling, select the unit position and airflow direction that enable the cool and warm air to spread out to the whole room.**
  - **Do not place objects that might obstruct the airflow within 1 m below the intake grill.**

#### Required Minimum Space for Installation and Service

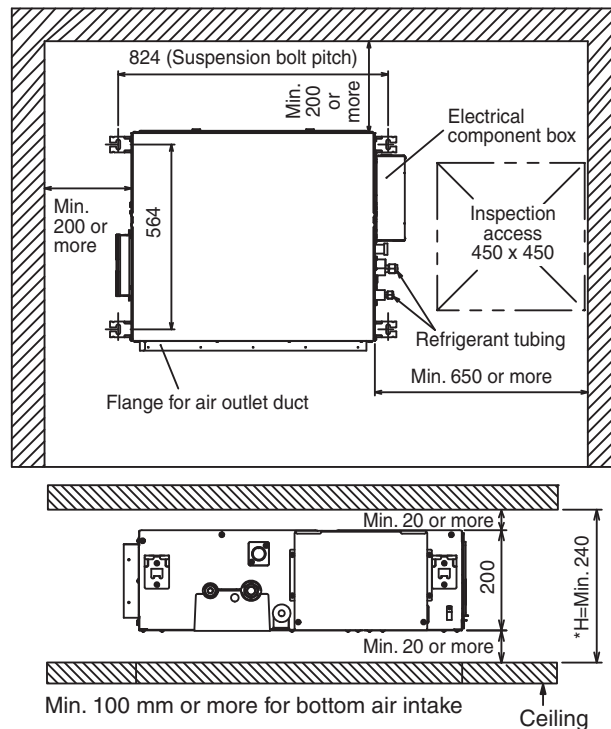

- H dimension means the minimum height of the unit installation space.
- Select H dimension such that a downward slope of at least 1/100 is ensured. Refer to 11.1.4 “Connecting the drain piping”

### Dimension of the Indoor Unit

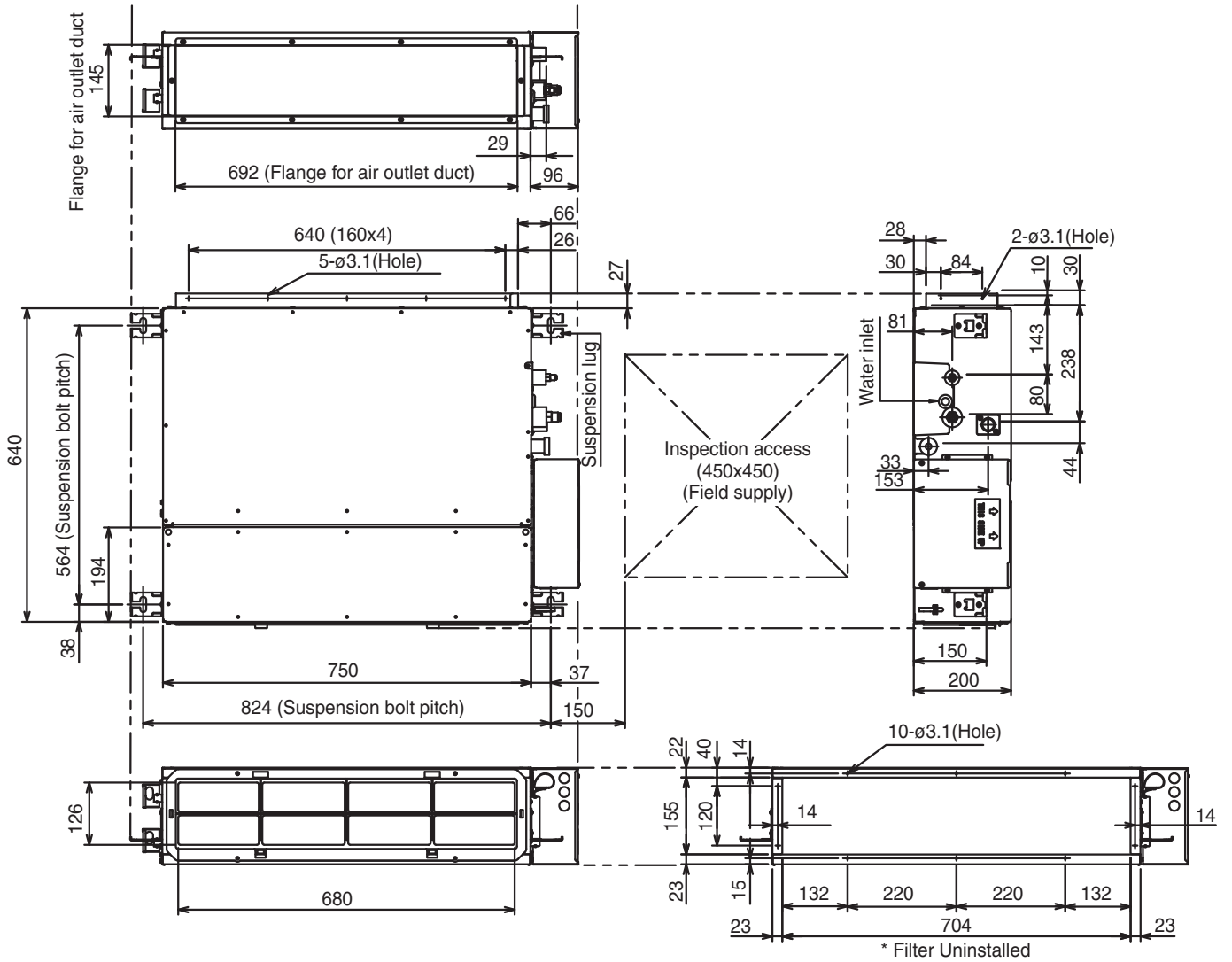

### In Case of Bottom Intake

- 1 Remove the frame filter assy as shown in diagram ①
- 2 Remove cover plate as shown in diagram ①
- 3 Fix frame filter assy as shown in diagram ②
- 4 Fix cover plate as shown in diagram ② with the dummy hole downward.

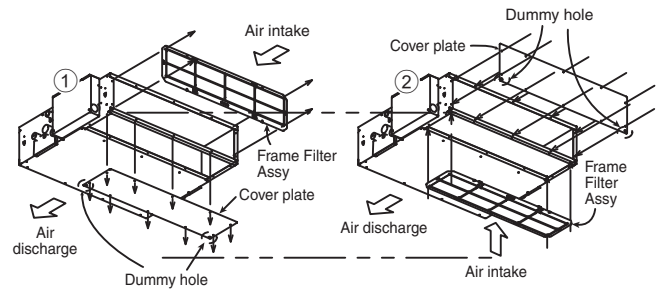

### Fixing Frame Filter Assy

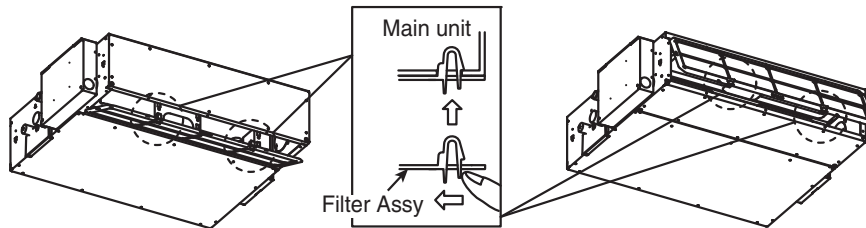

\* Attach the frame filter assy to the main unit while pushing the tip of the latches in the direction of the arrow.

## Ceiling Opening

- Install inspection opening (450 mm x 450 mm) on the control box side where maintenance and inspection of the control box and drain pump are easy. Install another inspection opening (800 mm x 700 mm) also at the lower part of the unit.

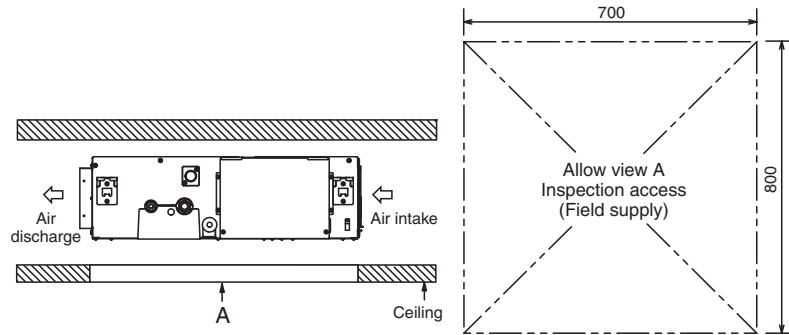

## Securing the Hanging Bolts

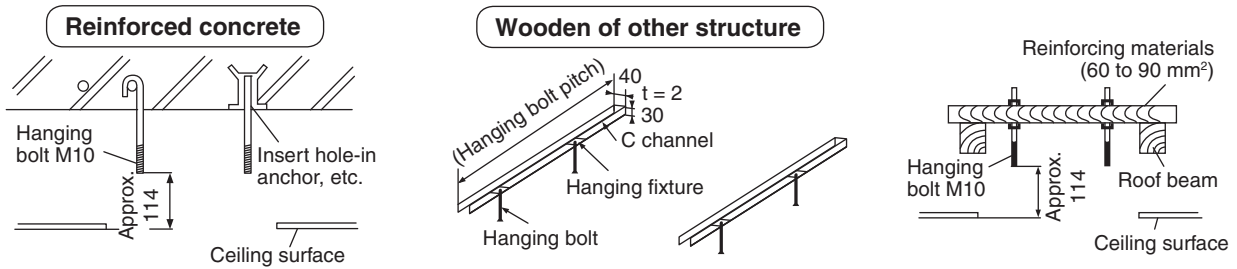

- Secure the hanging bolts (M10, locally purchased) firmly in a manner capable of supporting the unit weight.
- Consult your construction or interior contractor for details on finishing the ceiling opening.

## Installing an Intake and Discharge Duct Type

- Ensure the range of unit external static pressure is not exceeded. Refer technical manual for the range of external static pressure setting.
- Connect the duct as shown.
- When attaching duct to the intake side, remove the product filter frame assy and replace with locally purchase intake-side flange by using flange by using 10 - Ø 3.1(hole) screws.
- Wrap the flange and duct connection area with aluminium tape or similar to prevent air leak.

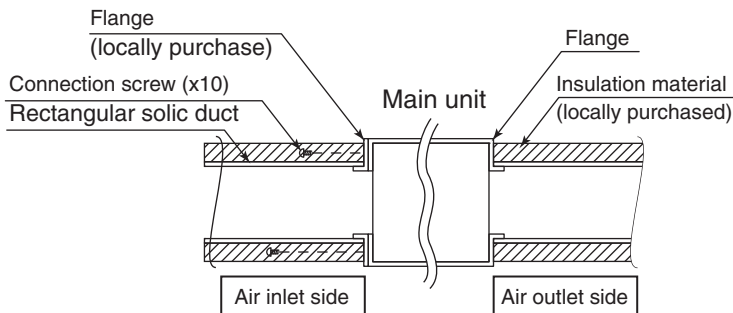

### CAUTION

When attaching a duct to the intake-side, be sure to attach an air filter inside the air passage on the intake-side. (Use an air filter with dust collecting efficiency at least 50% in a gravimetric technique.)



### Installation into the Ceiling

- Attach the nuts and washers to the hanging bolts, then lift up and hook the main unit onto the hanging fixtures.
- Check if the unit is leveled using a level or a vinyl hose filled partially with water.

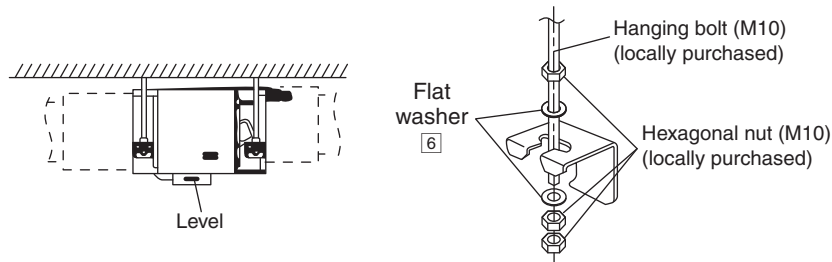

### Remote Controller Installation

- 1 Remove the remote controller **1** lower case. (Insert a flat-tipped screw driver or similar tool 2 to 3 mm into one of the gaps at the bottom of the case, and twist to open. Refer to the illustration at right.) Be careful not to damage the lower case.
- 2 Do not remove the protective tape which is affixed to the upper case circuit board when remove the remote controller lower case.
- 3 Secure the lower case to an outlet box or wall. Refer to (A) or (B) instructions below depending on your choice of cable installation.
- 4 Be sure to use only the screws provided.
- 5 Do not over tighten the screws, as it may result in damage to the lower case.
- 6 Connect the indoor unit and the remote controller **1**. (Refer to the illustration)
- 7 Insert firmly the connector of remote controller cable **2** to connector at control box of indoor unit.
- 8 Fix the green wire from remote controller cable **2** to the grounding location provided inside control board.

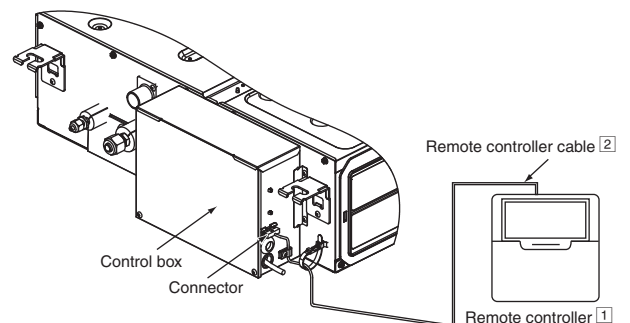
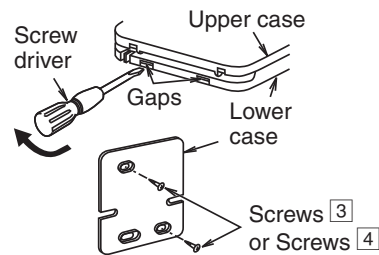

### A. IF REMOTE CONTROLLER CABLE IS EMBEDDED

- 1 Embed an outlet box (JIS C 8336) into the wall. Outlet box maybe purchased separately. Medium size square outlet box (obtain locally) Part No. DS3744 (Panasonic Co., Ltd.) or equivalent.
- 2 Secure the remote controller lower case to the outlet box with the two accessory screws [3]. Make sure that the lower case is flat against the wall at this time, with no bending.
- 3 Pass the remote controller cable [2] into the box.
- 4 Route the remote controller cable [2] inside the lower case through rear feeding-out direction.
- 5 Insert firmly the connector of remote controller cable [2] to connector (CON1) in the upper case circuit board.
- 6 Secure the remote controller upper case to the lower case with the tabs provided.

### ⚠ CAUTION

When the wall is hollow, please be sure to use the sleeve for remote controller cable to prevent dangers caused by mice biting the cable.

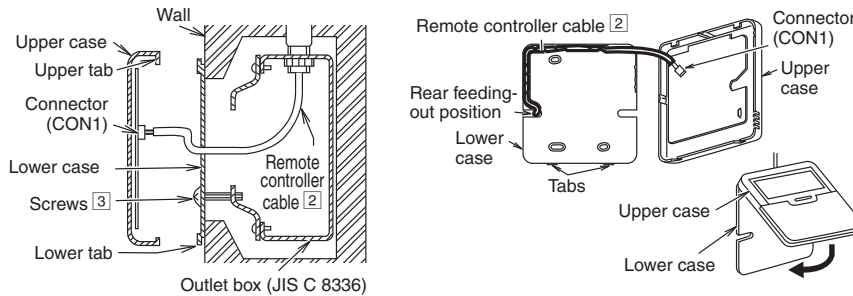

### B. IF REMOTE CONTROLLER CABLE IS EXPOSED

- 1 Install the remote controller lower case to the wall with the two accessory screws [4].
- 2 Fasten the screws properly until screw head is lower than the rib and reach the base of remote controller lower case to ensure they do not damage the PCB inside the remote controller [1].

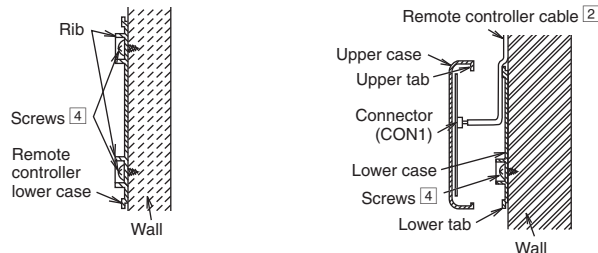

- 3 The feeding-out direction for the remote controller cable can be either via top, left or right side.
- 4 Use nipper to cut a notch at the upper case. (Select the intended feeding-out position)
- 5 Route the remote controller cable [2] inside the lower case in accordance with the intended feeding-out direction. (Refer to the illustration at below).
- 6 Insert firmly the connector of remote controller cable [2] to connector (CON1) in the upper case circuit board. (Refer to the illustration)
- 7 Secure the remote controller upper case to the lower case with the tabs provided.

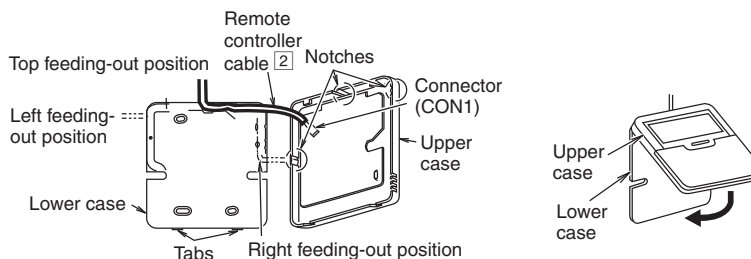

### 11.1.4 Connecting the Drain Piping

- Lay the drain piping so as to ensure drainage.
- Use a locally purchased VP20 general rigid PVC pipe (outer diameter  $\varnothing 26$ ) for the drain piping **and firmly connect the indoor unit and the drain piping using supplied hose band to ensure that no leakage occurs.**
- Drain piping located indoor should always be insulated by wrapping with locally purchased insulation (foamed polyethylene with a thickness of 10 mm or more).
- The drain piping should have a downward gradient (1/100 or more) and should be secured by using pipe hanging equipment to avoid creating hills or traps partway.
- Should there be any obstacle preventing the drain piping from being extended smoothly, the drain piping can be raised outside of the main unit as shown in the illustration below.

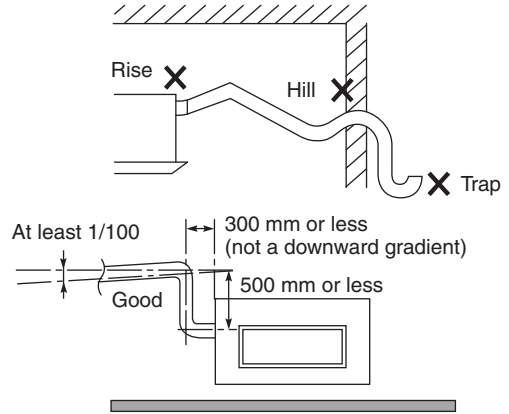
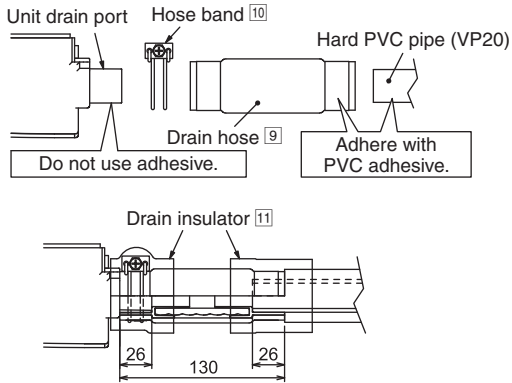

#### ⚠ CAUTION

- Strictly do not install and extend the drain piping from the main unit drain water outlet horizontally or upward or raised it 50 cm or more. Doing so may result in poor drainage or drain motor failure.
- Do not use drain hose bent at 90° angle. (The maximum permissible bend is 45°.)

### 11.1.5 Insulating the Refrigerant

- After the piping is connected, insulate. (Refer to the illustration)

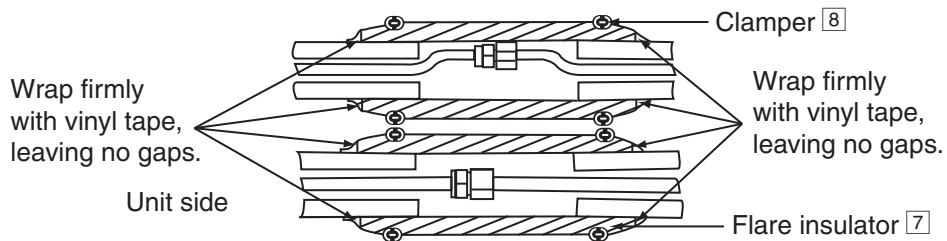

### 11.1.6 Connecting the Indoor/Outdoor Connection Cable

- Remove the control box cover and insert the connection cable into the control box.
- Check the color of the wires on the terminal board and secure them with screws.
- Secure the outer sheath of the connection cable with the cord clamp.
- Reattach the control box cover to its original position.





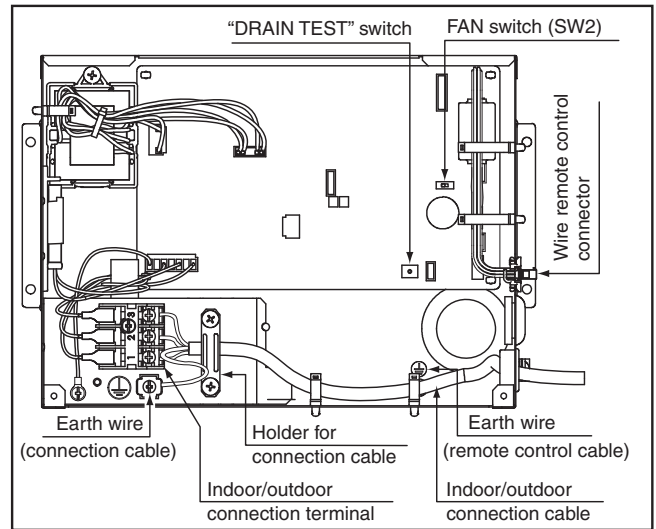

- Ensure the colour of wires of outdoor unit and the terminal Nos. are the same to the indoor's respectively.
- Earth wire shall be Yellow/Green (Y/G) in colour and longer than other AC wires for safety reason.

**CAUTION**  
When the wall is hollow, please be sure to use the sleeve for tube ass'y to prevent dangers caused by mice biting the connection cable.

- Connection cable between indoor unit and outdoor unit should be approved polychloroprene sheathed 4 x 1.5 mm<sup>2</sup> flexible cord, designation type 60245 IEC 57 (H05RN-F) or heavier cord. Allowable connection cable length of each indoor unit shall be 30 m or less.
  - Ensure that the terminal numbers on the indoor unit are connected to the same terminal numbers on the outdoor unit by the right coloured wires as shown in the diagram.
  - Earth lead wire should be longer than the other lead wires as shown in the diagram for electrical safety purpose in case the cord slips out from the anchorage.
  - Secure the cable onto the control board with the holder (clammer).

**WARNING**  
This equipment must be properly earthed.



Terminals on the indoor unit	1	2	3	
Colour of wires				
Terminals on the outdoor unit	1	2	3	

### 11.1.6.1 Wire Stripping and Connecting Requirement

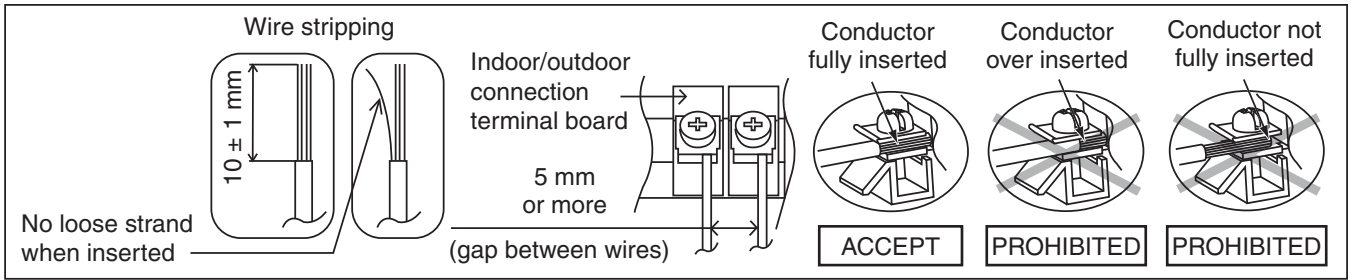

Do not joint wires

**WARNING**

**RISK OF FIRE**  
JOINING OF WIRES MAY CAUSE OVERHEATING AND FIRE.

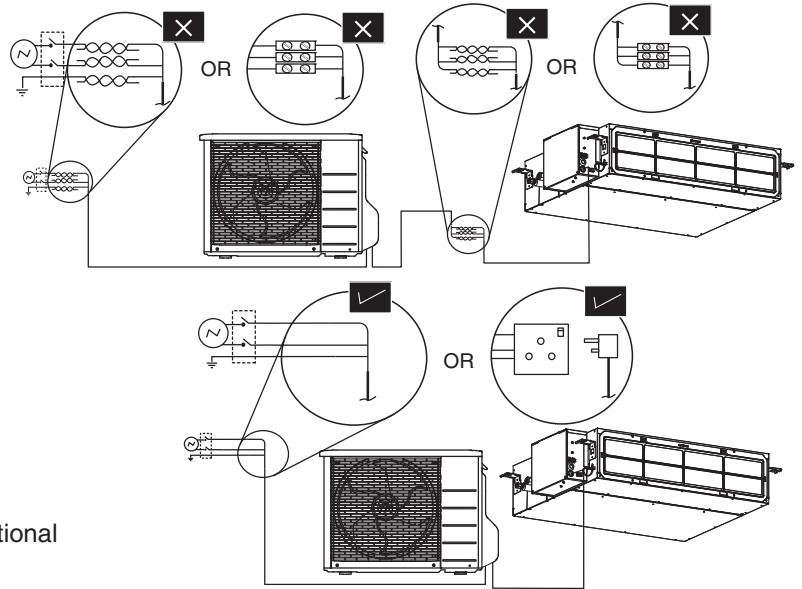

- ❗ Use complete wire without joining.
- ❗ Use approved socket and plug with earth pin.
- ❗ Wire connection in this area must follow to national wiring rules.

## 11.2 Outdoor Unit

### 11.2.1 Selecting the Installation Location

- If an awning is built over the unit to prevent direct sunlight or rain, be careful that heat radiation from the condenser is not obstructed.
- There should not be any animal or plant which could be affected by hot air discharged.
- Keep the spaces indicated by arrows from wall, ceiling, fence or other obstacles.
- Do not place any obstacles which may cause a short circuit of the discharged air.
- If piping length is over the [piping length for additional gas], additional refrigerant should be added as shown in the table.

Model	Horse Power (HP)	Piping size		Std. Length (m)	Max. Elevation (m)	Min. Piping Length (m)	Max. Piping Length (m)	Additional Refrigerant (g/m)	Piping Length for add. gas (m)
		Gas	Liquid						
E18****	2.0HP	12.7 mm (1/2")	6.35 mm (1/4")	5	20	3	30	20	10

Example: For E18\*\*\*\*

If the unit is installed at 12 m distance, the quantity of additional refrigerant should be 40 g .... (12-10) m x 20 g/m = 40 g.

### 11.2.2 Install the Outdoor Unit

At the best location, start installation according to Indoor-Outdoor Unit Installation Diagram.

- 1 Fix the unit on concrete or rigid frame firmly and horizontally by bolt nut (ø10 mm).
- 2 When installing at roof, please consider strong wind. Please fasten the installation stand firmly with bolt or nails.

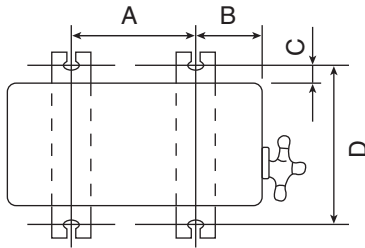

Model	A	B	C	D
E18****	613 mm	130 mm	24 mm	360.5 mm

### 11.2.3 Connect the Piping

#### 11.2.3.1 Connecting the Piping to Indoor Unit

Please make flare after inserting flare nut (locate at joint portion of tube assembly) onto the copper pipe. (In case of using long piping)

Connect the piping

- Align the center of piping and sufficiently tighten the flare nut with fingers.
- Further tighten the flare nut with torque wrench in specified torque as stated in the table.

Do not overtighten, overtightening may cause gas leakage.

Piping size	Torque
6.35 mm (1/4")	[18 N•m (1.8 kgf•m)]
9.52 mm (3/8")	[42 N•m (4.3 kgf•m)]
12.7 mm (1/2")	[55 N•m (5.6 kgf•m)]
15.88 mm (5/8")	[65 N•m (6.6 kgf•m)]
19.05 mm (3/4")	[100 N•m (10.2 kgf•m)]

#### 11.2.3.2 Connecting the Piping to Outdoor Unit

Decide piping length and then cut by using pipe cutter. Remove burrs from cut edge.

Make flare after inserting the flare nut (locate at valve) onto the copper pipe.

Align center of piping to valve and then tighten with torque wrench to the specified torque as stated in the table.

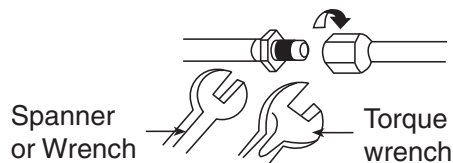

### 11.2.3.3 Connecting the Piping to Outdoor Multi

Decide piping length and then cut by using pipe cutter.  
Remove burrs from cut edge.  
Make flare after inserting the flare nut (locate at valve)  
onto the copper pipe.  
Align center of piping to valve and then tighten with  
torque wrench to the specified torque as stated in the  
table.

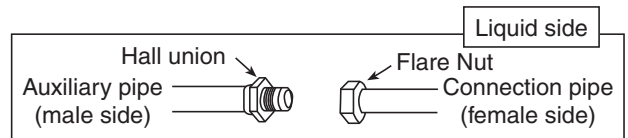

\* For Gas side piping please refer table and diagram below

Outdoor Multi combination model		Gas side	
CS-E18****	CU-3E18***, CU-4E23*** CU-4E27***, CU-5E34***	Auxiliary pipe (male side)	Connection pipe (female side)

Hall union

Packing

Pipe size reducer (CZ-MA1P)

Flare Nut

\* Kindly consult authorised dealer for connectivity validity.

### 11.2.4 Evacuation of the Equipment

WHEN INSTALLING AN AIR CONDITIONER, BE SURE TO EVACUATE THE AIR INSIDE THE INDOOR UNIT AND PIPES in the following procedure.

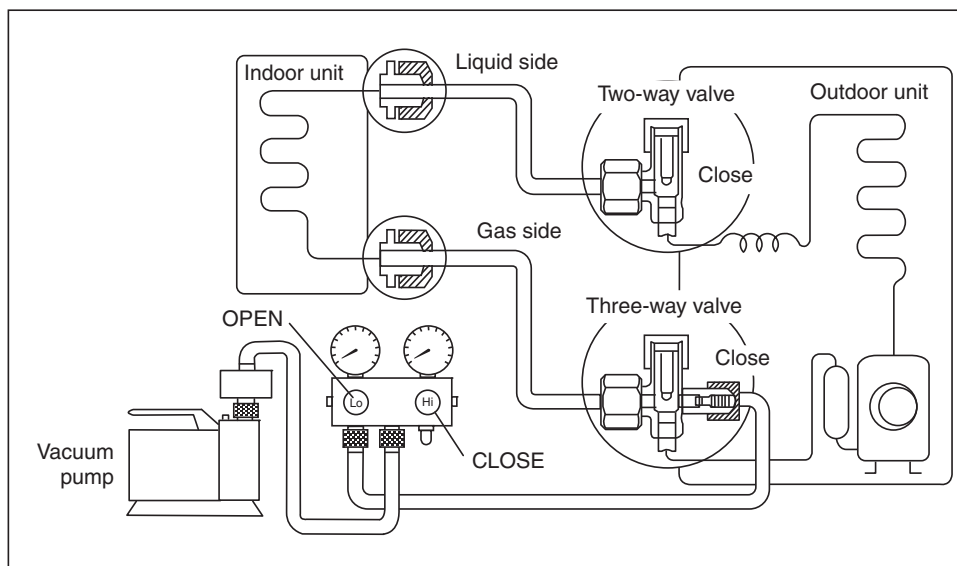

- 1 Connect a charging hose with a push pin to the Low side of a charging set and the service port of the 3-way valve.
  - o Be sure to connect the end of the charging hose with the push pin to the service port.
- 2 Connect the center hose of the charging set to a vacuum pump.
- 3 Turn on the power switch of the vacuum pump and make sure that the needle in the gauge moves from 0 cmHg (0 MPa) to -76 cmHg (-0.1 MPa). Then evacuate the air approximately ten minutes.
- 4 Close the Low side valve of the charging set and turn off the vacuum pump. Make sure that the needle in the gauge does not move after approximately five minutes.  
Note: BE SURE TO TAKE THIS PROCEDURE IN ORDER TO AVOID REFRIGERANT GAS LEAKAGE.
- 5 Disconnect the charging hose from the vacuum pump and from the service port of the 3-way valve.
- 6 Tighten the service port caps of the 3-way valve at a torque of 18 N•m with a torque wrench.
- 7 Remove the valve caps of both of the 2-way valve and 3-way valve. Position both of the valves to "OPEN" using a hexagonal wrench (4 mm).
- 8 Mount valve caps onto the 2-way valve and the 3-way valve.
  - o Be sure to check for gas leakage.

- If gauge needle does not move from 0 cmHg (0 MPa) to -76 cmHg (-0.1 MPa), in step ③ above take the following measure:
  - If the leak stops when the piping connections are tightened further, continue working from step ③.
  - If the leak does not stop when the connections are retightened, repair location of leak.
  - Do not release refrigerant during piping work for installation and reinstallation.
  - Take care of the liquid refrigerant, it may cause frostbite.

## 11.2.5 Connect the cable to the Outdoor Unit

(FOR DETAIL REFER TO WIRING DIAGRAM AT UNIT)

- 1 Remove the control board cover from the unit by loosening the screw.
- 2 Cable connection to the power supply through Isolating Devices (Disconnecting means).
  - Connect approved type polychloroprene sheathed **power supply cord** 3 x 2.5 mm<sup>2</sup> type designation 60245 IEC 57 or heavier cord to the terminal board, and connect the others end of the cord to Isolating Devices (Disconnecting means).
- 3 **Connection cable** between indoor unit and outdoor unit shall be approved polychloroprene sheathed 4 x 1.5 mm<sup>2</sup> flexible cord, type designation 60245 IEC 57 or heavier cord. Allowable connection cable length of each indoor unit shall be 30 m or less.
- 4 Connect the power supply cord and connection cable between indoor unit and outdoor unit according to the diagram below.

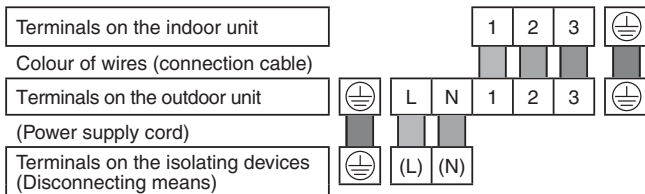

- 5 Secure the power supply cord and connection cable onto the control board with the holder.
- 6 Attach the control board cover back to the original position with screw.
- 7 For wire stripping and connection requirement, refer to instruction 11.1.6 of indoor unit.

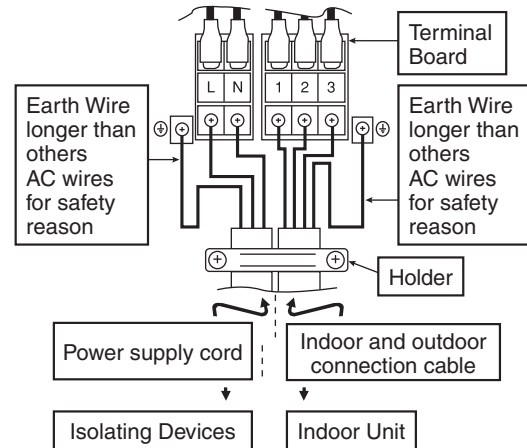

**WARNING**

⚡ This equipment must be properly earthed.

Note:

- Isolating Devices (Disconnecting means) should have minimum 3.0 mm contact gap.
- Earth wire shall be Yellow/Green (Y/G) in colour and longer than other AC wires for safety reason.

## 11.2.6 Piping Insulation

- 1 Please carry out insulation at pipe connection portion as mentioned in Indoor/Outdoor Unit Installation Diagram. Please wrap the insulated piping end to prevent water from going inside the piping.
- 2 If drain hose or connecting piping is in the room (where dew may form), please increase the insulation by using POLY-E FOAM with thickness 8 mm or above.

### 11.2.6.1 Cutting and Flaring the Piping

- 1 Please cut using pipe cutter and then remove the burrs.
- 2 Remove the burrs by using reamer. If burrs is not removed, gas leakage may be caused. Turn the piping end down to avoid the metal powder entering the pipe.
- 3 Please make flare after inserting the flare nut onto the copper pipes.

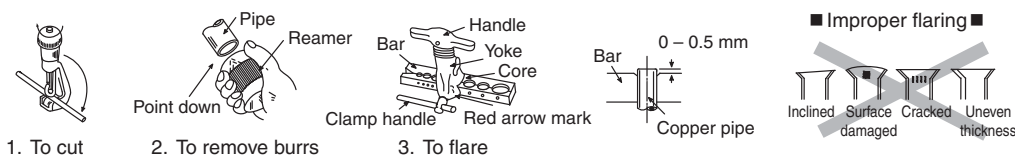

When properly flared, the internal surface of the flare will evenly shine and be of even thickness. Since the flare part comes into contact with the connections, carefully check the flare finish.



### Switching the High State Switch (SW2)

- To increase the air volume, open the control box and on the control board, switch the FAN switch (SW2) to “HI”.
- See the diagram for “Connecting the Indoor/Outdoor Connection Cable”.

### Note: Enabling Long-range Remote Control

- To maintain EMC emission limits, cabling interconnecting the HA terminal and subsequent opto-coupler, must be no more than 1.9 m length.
- Loop four turns of this cable through a suitable small EMC ferrite toroid, and protect with a short length of large diameter heat-shrink tube.
- There is no similar length limit for cable following on from the opto-coupler isolation.

### CHECK THE DRAINAGE

#### Check after connecting the power supply.

- Pour approximately 600 cc of water into the drain pan of the main unit using a squeeze bottle, etc.
- Press the drain test run switch on the control board in the control box to start the drain motor and check whether the water drains normally. (The drain motor operates for approximately 5 minutes and then stops automatically.) (See the diagram for “Connecting the Indoor/Outdoor Connection Cable”.)

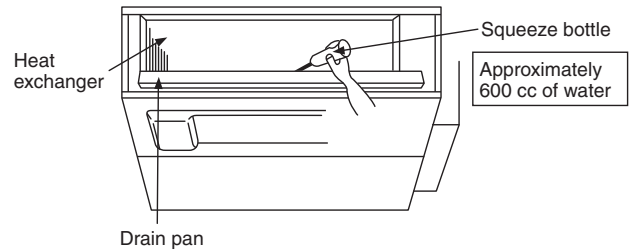

### DISPOSAL OF OUTDOOR UNIT DRAIN WATER

- If a drain elbow is used, the unit should be placed on a stand which is taller than 30 mm.
- If the unit is used in an area where temperature falls below 0°C for 2 or 3 days in succession, it is recommended not to use a drain elbow, for the drain water freezes and the fan will not rotate.

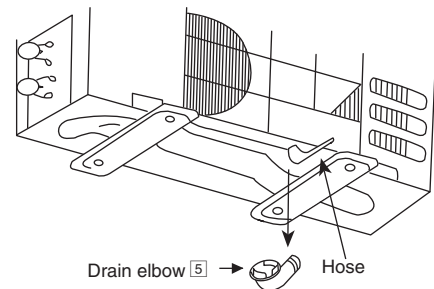

## 12. Operation and Control

### 12.1 Basic Function

Inverter control, which equipped with a microcomputer in determining the most suitable operating mode as time passes, automatically adjusts output power for maximum comfort always. In order to achieve the suitable operating mode, the microcomputer maintains the set temperature by measuring the temperature of the environment and performing temperature shifting. The compressor at outdoor unit is operating following the frequency instructed by the microcomputer at indoor unit that judging the condition according to internal setting temperature and intake air temperature.

#### 12.1.1 Internal Setting Temperature

Once the operation starts, remote control setting temperature will be taken as base value for temperature shifting processes. These shifting processes are depending on the air conditioner settings and the operation environment. The final shifted value will be used as internal setting temperature and it is updated continuously whenever the electrical power is supplied to the unit.

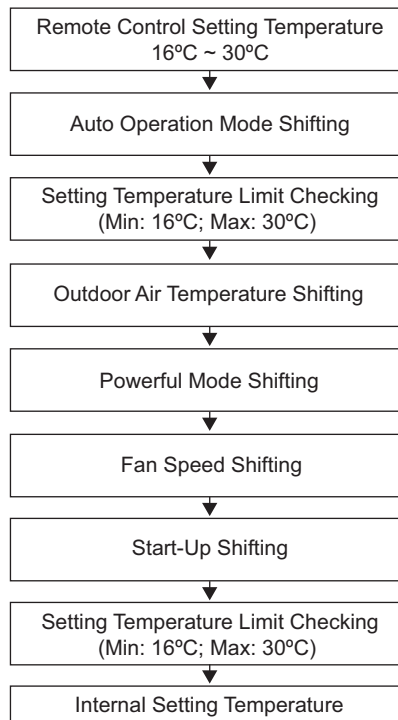

#### 12.1.2 Cooling Operation

##### 12.1.2.1 Thermostat control

- Compressor is OFF when Intake Air Temperature - Internal Setting Temperature < -2.0°C continue for 3 minutes.
- Compressor is ON after waiting for 3 minutes, if the Intake Air Temperature - Internal Setting Temperature > Compressor OFF point.

#### 12.1.3 Soft Dry Operation

##### 12.1.3.1 Thermostat control

- Compressor is OFF when Intake Air Temperature - Internal Setting Temperature < -2.0°C continue for 3 minutes.
- Compressor is ON after waiting for 3 minutes, if the Intake Air Temperature - Internal Setting Temperature > Compressor OFF point.

## 12.1.4 Heating Operation

### 12.1.4.1 Thermostat control

- Compressor is OFF when Intake Air Temperature - Internal Setting Temperature  $> +2.0^{\circ}\text{C}$ .
- Compressor is ON after waiting for 3 minutes, if the Intake Air Temperature - Internal Setting Temperature  $<$  Compressor OFF point.

## 12.1.5 Automatic Operation

- This mode can be set using remote control and the operation is decided by remote control setting temperature, remote control operation mode and indoor intake air temperature.
- During operation mode judgment, indoor fan motor (with speed of Lo-) is running for 30 seconds to detect the indoor intake air temperature.
- Every 10 minutes, the indoor temperature is judged.
- For the 1st judgment
  - If indoor intake temperature - remote control setting temperature  $\geq 2^{\circ}\text{C}$ , COOL mode is decided.
  - If  $-2^{\circ}\text{C} \leq$  indoor intake temperature - remote control setting temperature  $< 2^{\circ}\text{C}$ , DRY mode is decided.
  - If indoor intake temperature - remote control setting temperature  $< -2^{\circ}\text{C}$ , HEAT mode is decided.

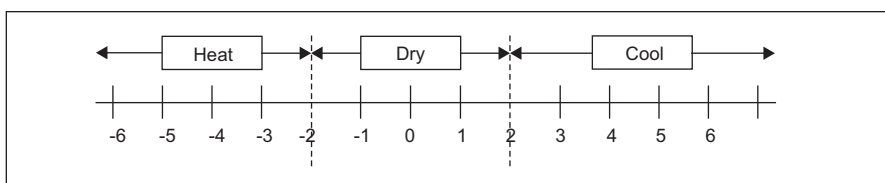

- For the 2nd judgment onwards
  - If indoor intake temperature - remote control setting temperature  $\geq 3^{\circ}\text{C}$ , if previous operate in DRY mode, then continue in DRY mode. Otherwise COOL mode is decided.
  - If  $-2^{\circ}\text{C} \leq$  indoor intake temperature - remote control setting temperature  $< 3^{\circ}\text{C}$ , maintain with previous mode.
  - If indoor intake temperature - remote control setting temperature  $< -2^{\circ}\text{C}$ , HEAT mode is decided.

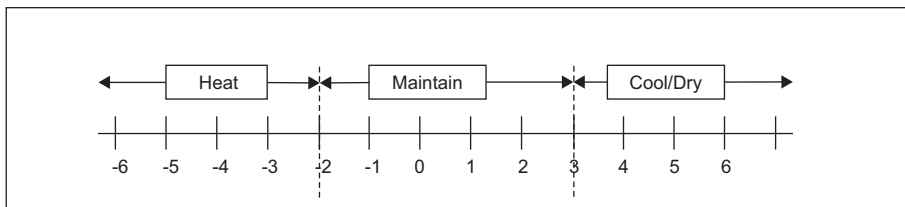

## 12.1.6 Indoor Fan Motor Operation

### A. Basic Rotation Speed (rpm)

#### i. Manual Fan Speed

[Cooling, Dry]

- Fan motor's number of rotation is determined according to remote control setting.

Remote Control	O	O	O	O	O
Tab (rpm)	Hi	Me+	Me	Me-	Lo

[Heating]

- Fan motor's number of rotation is determined according to remote control setting.

Remote Control	O	O	O	O	O
Tab (rpm)	Shi	Me+	Me	Me-	Lo

#### ii. Auto Fan Speed

[Cooling, Dry]

- According to room temperature and setting temperature, indoor fan speed is determined automatically.

- The indoor fan will operate according to pattern below.

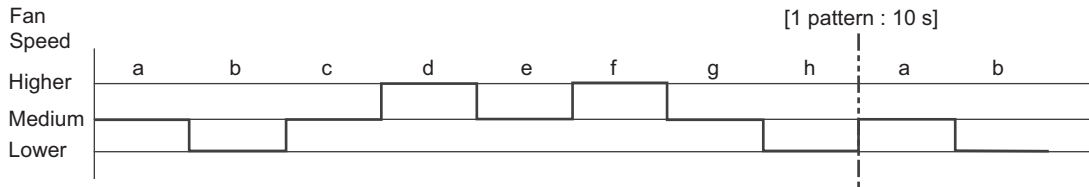

[Heating]

- According to indoor pipe temperature, automatic heating fan speed is determined as follows.

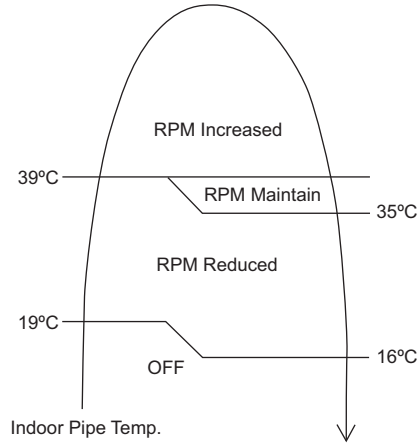

### B. Feedback control

- Immediately after the fan motor started, feedback control is performed once every second.
- During fan motor on, if fan motor feedback  $\geq 2550$  rpm or  $< 50$  rpm continue for 10 seconds, then fan motor error counter increase, fan motor is then stop and restart. If the fan motor counter becomes 7 times, then H19 - fan motor error is detected. Operation stops and cannot on back.

### 12.1.7 Outdoor Fan Motor Operation

Outdoor fan motor is operated with 15 fan speed. It starts when compressor starts operation and it stops 30 seconds after compressor stops operation.

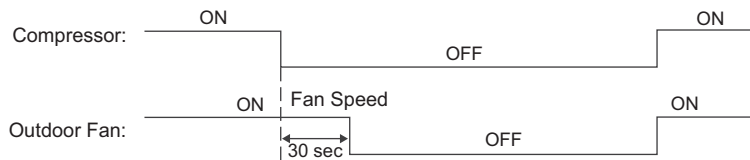

## 12.2 Quiet Operation (Cooling Mode/Cooling Area of Soft Dry Mode)

### A. Purpose

To provide quiet cooling operation compare to normal operation.

### B. Control condition

#### a. Quiet operation start condition

- When “quiet” button at remote control is pressed.  
Quiet LED illuminates.

#### b. Quiet operation stop condition

- 1 When one of the following conditions is satisfied, quiet operation stops:
  - a. Powerful button is pressed.
  - b. Stop by OFF/ON switch.
  - c. Timer “off” activates.
  - d. Quiet button is pressed again.
- 2 When quiet operation is stopped, operation is shifted to normal operation with previous setting.
- 3 When fan speed is changed, quiet operation is shifted to quiet operation of the new fan speed.
- 4 When operation mode is changed, quiet operation is shifted to quiet operation of the new mode.
- 5 During quiet operation, if timer “on” activates, quiet operation maintains.
- 6 After off, when on back, quiet operation is not memorised.

### C. Control contents

- 1 Auto fan speed is changed from normal setting to quiet setting of respective fan speed.  
This is to reduce sound of Hi, Me, Lo for 3dB.
- 2 Manual fan speed for quiet operation is 1 step from setting fan speed.
- 3 Compressor frequency reduced.

## 12.2.1 Quiet operation (Heating)

### A. Purpose

To provide quiet heating operation compare to normal operation.

### B. Control condition

#### a. Quiet operation start condition

- When “quiet” button at remote control is pressed.  
Quiet LED illuminates.

#### b. Quiet operation stop condition

- 1 When one of the following conditions is satisfied, quiet operation stops:
  - a. Powerful button is pressed.
  - b. Stop by OFF/ON switch.
  - c. Timer “off” activates.
  - d. Quiet button is pressed again.
- 2 When quiet operation is stopped, operation is shifted to normal operation with previous setting.
- 3 When fan speed is changed, quiet operation is shifted to quiet operation of the new fan speed.
- 4 When operation mode is changed, quiet operation is shifted to quiet operation of the new mode, except fan only mode.
- 5 During quiet operation, if timer “on” activates, quiet operation maintains.
- 6 After off, when on back, quiet operation is not memorised.

### C. Control contents

#### a. Fan Speed Auto

- Indoor FM RPM depends on pipe temperature sensor of indoor heat exchanger.  
Auto fan speed is changed from normal setting to quiet setting of respective fan speed.  
This is to reduce sound of Hi, Me, Lo for 3dB.

#### b. Fan Speed Manual

- Manual fan speed for quiet operation is - 1 step from setting fan speed.

#### c. Compressor frequency reduced.

## 12.3 Powerful Mode Operation

When the powerful mode is selected, the internal setting temperature will shift higher up to +6.0°C (for Heating) or lower up to 4°C (for Cooling/Soft Dry) than remote control setting temperature for 20 minutes to achieve the setting temperature quickly.

## 12.4 Timer Control

### 12.4.1 ON Timer Control

ON timer can be set using remote control, the unit with timer set will start operate earlier than the setting time. This is to provide a comfortable environment when reaching the set ON time.

60 minutes before the set time, indoor (at fan speed of Lo-) and outdoor fan motor start operate for 30 seconds to determine the indoor intake air temperature and outdoor air temperature in order to judge the operation starting time.

From the above judgment, the decided operation will start operate earlier than the set time as shown below.

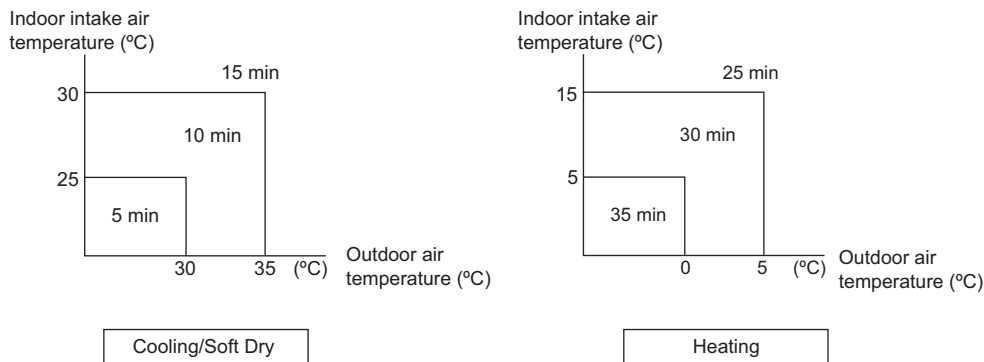

### 12.4.2 OFF Timer Control

OFF timer can be set using remote control, the unit with timer set will stop operate at set time.

## 12.5 Auto Restart Control

- 1 When the power supply is cut off during the operation of air conditioner, the compressor will re-operate within three to four minutes (there are 10 patterns between 2 minutes 58 seconds and 3 minutes 52 seconds to be selected randomly) after power supply resumes.
- 2 This type of control is not applicable during ON/OFF Timer setting.
- 3 This control can be omitted by open the circuit of JP10 at indoor unit printed board.

## 12.6 Indication Panel

LED	OFF/ON Operation
Color	Green
Light ON	Operation ON
Light OFF	Operation OFF

Note:

- If OFF/ON operation LED is OFF and OFF indicator does not shown on remote control display, there is an abnormality operation occurs.

# 13. Protection Control

## 13.1 Protection Control For All Operations

### 13.1.1 Restart Control (Time Delay Safety Control)

- The Compressor will not turn on within 3 minutes from the moment operation stops, although the unit is turned on again by pressing OFF/ON button at remote control within this period.
- This control is not applicable if the power supply is cut off and on again.
- This phenomenon is to balance the pressure inside the refrigerant cycle.

### 13.1.2 30 Seconds Forced Operation

- Once the air conditioner is turned on, the compressor will not stop within 30 seconds in a normal operation although the intake air temperature has reached the thermo-off temperature. However, force stop by pressing the OFF/ON button at the remote control is permitted or the Auto OFF/ON button at indoor unit.
- The reason for the compressor to force operation for minimum 30 seconds is to allow the refrigerant oil run in a full cycle and return back to the outdoor unit.

### 13.1.3 Total Running Current Control

- 1 When the outdoor unit total running current (AC) exceeds X value, the frequency instructed for compressor operation will be decreased.
- 2 If the running current does not exceed X value for five seconds, the frequency instructed will be increased.
- 3 However, if total outdoor unit running current exceeds Y value, compressor will be stopped immediately for 3 minutes.

Operation mode	E18RD3EAW	
	X (A)	Y (A)
Cooling/Soft Dry (A)	10.47	14.75
Cooling/Soft Dry (B/C)	9.74	14.75
Heating	9.57	14.75

- 4 The first 30 minutes of cooling operation, (A) will be applied.

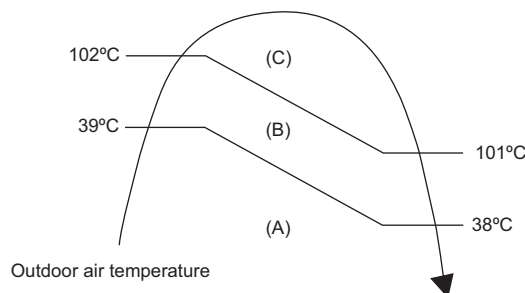

### 13.1.4 IPM (Power transistor) Prevention Control

- Overheating Prevention Control
  - 1 When the IPM temperature rises to 120°C, compressor operation will stop immediately.
  - 2 Compressor operation restarts after three minutes the temperature decreases to 110°C.
- DC Peak Current Control
  - 1 When electric current to IPM exceeds set value of 30.0 ± 5.0 A, the compressor will stop operate. Then, operation will restart after three minutes.
  - 2 If the set value is exceeded again more than 30 seconds after the compressor starts, the operation will restart after two minutes.
  - 3 If the set value is exceeded again within 30 seconds after the compressor starts, the operation will restart after one minute. If this condition repeats continuously for seven times, all indoor and outdoor relays will be cut off.

### 13.1.5 Compressor Overheating Prevention Control

Instructed frequency for compressor operation will be regulated by compressor top temperature. The changes of frequency are as below figure.  
If compressor temperature exceeds 107°C, compressor will be stop, occurs 4 times per 20 minutes, timer LED will be blinking ("F97" is to be confirmed).

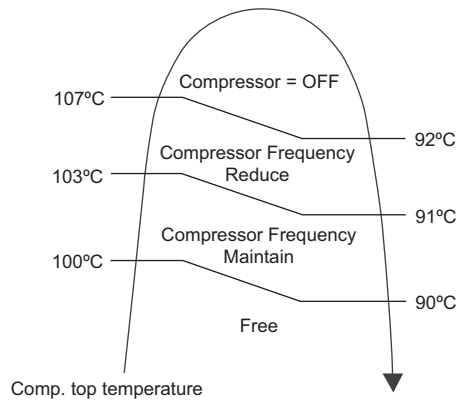

## 13.2 Protection Control For Cooling & Soft Dry Operation

### 13.2.1 Outdoor Air Temperature Control

The compressor operating frequency is regulated in accordance to the outdoor air temperature as shown in the diagram below.

This control will begin 1 minute after the compressor starts.  
Compressor frequency will adjust base on Outdoor Air Temperature.

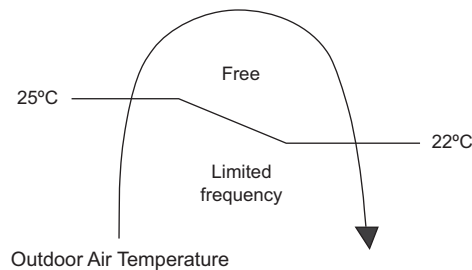



### 13.2.2 Cooling Overload Control

#### i. Pipe temperature limitation/restriction

- Detects the Outdoor pipe temperature and carry out below restriction/limitation (Limit the compressor Operation frequency)
- The compressor stop if outdoor pipe temperature exceeds 63°C.
- If the compressor stops 4 times in 20 minutes, Timer LED blinking (F95: outdoor high pressure rise protection)

### 13.2.3 Dew Prevention Control 1

- 1 To prevent dew formation at indoor unit discharge area.
- 2 This control activated if:
  - Outdoor air temperature and Indoor pipe temperature judgment by microcontroller if fulfilled.
  - When Cooling or Dry mode is operated more than 20 minutes or more.
- 3 This control stopped if:
  - Compressor stopped.
  - Remote control setting changed. (fan speed / temperature)
  - Outdoor air temperature and indoor intake temperature changed.

### 13.2.4 Dew Prevention Control 2

- 1 To prevent dew formation at indoor unit discharge area.
- 2 This control starts if all conditions continue for 20 minutes:
  - Operated with Cooling or Soft Dry Mode.
  - Indoor intake temperature is between 25°C and 29°C.
  - Outdoor air temperature is less than 30°C.
  - Quiet Lo fan speed.
- 3 This control stopped if:
  - When receive air swing change signal from Remote Control.

### 13.2.5 Freeze Prevention Control

- 1 When indoor heat exchanger temperature is lower than 0°C continuously for six minutes, compressor will stop operating.
- 2 Compressor will resume its operation 3 minutes after the indoor heat exchanger is higher than 5°C.
- 3 At the same time, indoor fan speed will be higher than during its normal operation.
- 4 If indoor heat exchanger temperature is higher than 13°C, the fan speed will return to its normal operation.

## 13.3 Protection Control For Heating Operation

### 13.3.1 Intake Air Temperature Control

Compressor will operate at maximum frequency if below conditions occur:

- 1 When the indoor intake air temperature is 30°C or above.

### 13.3.2 Outdoor Air Temperature Control

The maximum current value is regulated when the outdoor air temperature rises above 14°C in order to avoid compressor overloading.

### 13.3.3 Overload Protection Control

The compressor operating frequency is regulated in accordance to indoor heat exchanger temperature as shown in below figures.

If the heat exchanger temperature exceeds 60°C, compressor will stop.

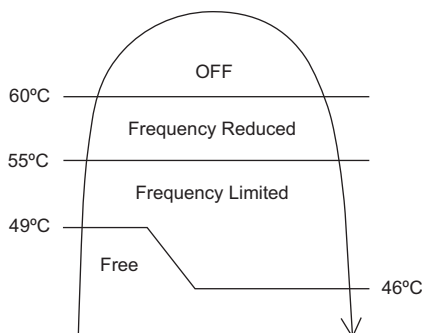

### 13.3.4 Cold Draught Operation

When indoor pipe temperature is low, cold draught operation start where indoor fan speed will be reduced.

### 13.3.5 Deice Operation

When outdoor pipe temperature and outdoor temperature is low, deice operation start where indoor fan motor and outdoor fan motor stop and operation LED blinks.

### 13.3.6 Drain Pump Control

- This unit has built-in with drain pump.

Control content

- During COOL/DRY mode.
  - During COOL/DRY mode, drain pump starts 10 seconds after indoor fan motor starts.
  - The drain pump turns ON and turns OFF periodically. (ON or OFF duration depends on room temperature).
- After COOL/DRY mode, when unit turns OFF (power standby) or changes to HEAT mode.
  - The drain pump turns ON for 60 seconds immediately.
- Error judgment
  - When float switch detects ON signal continuously for 2 minutes 30 seconds, error code H21 are shown.
  - When float switch ON has operated 2 times within 20 minutes, error code H35 are shown.

### **13.3.7 Pump Down Operation By CN-S**

- A convenience method to activate pump down operation.
- Control start condition:
  - During power standby condition, short CN-S continuously between 1 second and 10 seconds.
- Control stop condition:
  - 480 seconds after pump down operation starts.
  - CN-S is shorted again during pump down operation.

## 14. Servicing Mode

### 14.1 TEST RUN OPERATION (FOR PUMP DOWN/SERVICING PURPOSE)

- The Test Run operation will be activated by short-circuiting CN-S (Pin 1 & 2) at outdoor unit PCB after power supplied to outdoor unit terminal 1 and 2. The unit forced to run rated frequency cooling operation mode.

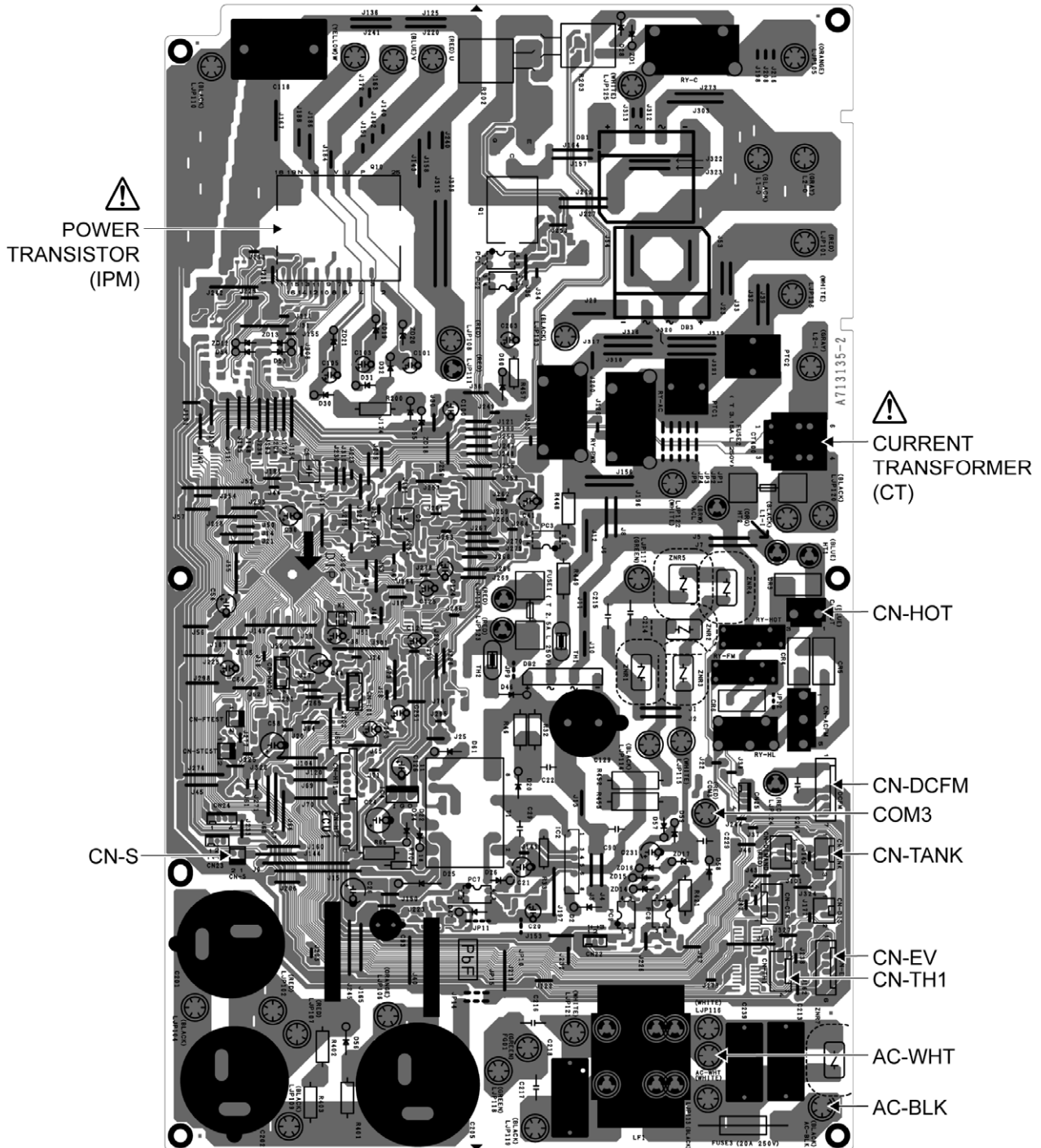

# 15. Troubleshooting Guide

## 15.1 Refrigeration Cycle System

In order to diagnose malfunctions, make sure that there are no electrical problems before inspecting the refrigeration cycle. Such problems include insufficient insulation, problem with the power source, malfunction of a compressor and a fan.

The normal outlet air temperature and pressure of the refrigeration cycle depends on various conditions, the standard values for them are shown in the table on the right.

Normal Pressure and Outlet Air Temperature (Standard)

	Gas pressure MPa (kg/cm <sup>2</sup> G)	Outlet air temperature (°C)
Cooling Mode	0.9 ~ 1.2 (9 ~ 12)	12 ~ 16
Heating Mode	2.3 ~ 2.9 (23 ~ 29)	36 ~ 45

- \*Condition:
- Indoor fan speed; High
  - Outdoor temperature 35°C at cooling mode and 7°C at heating mode
  - Compressor operates at rated frequency

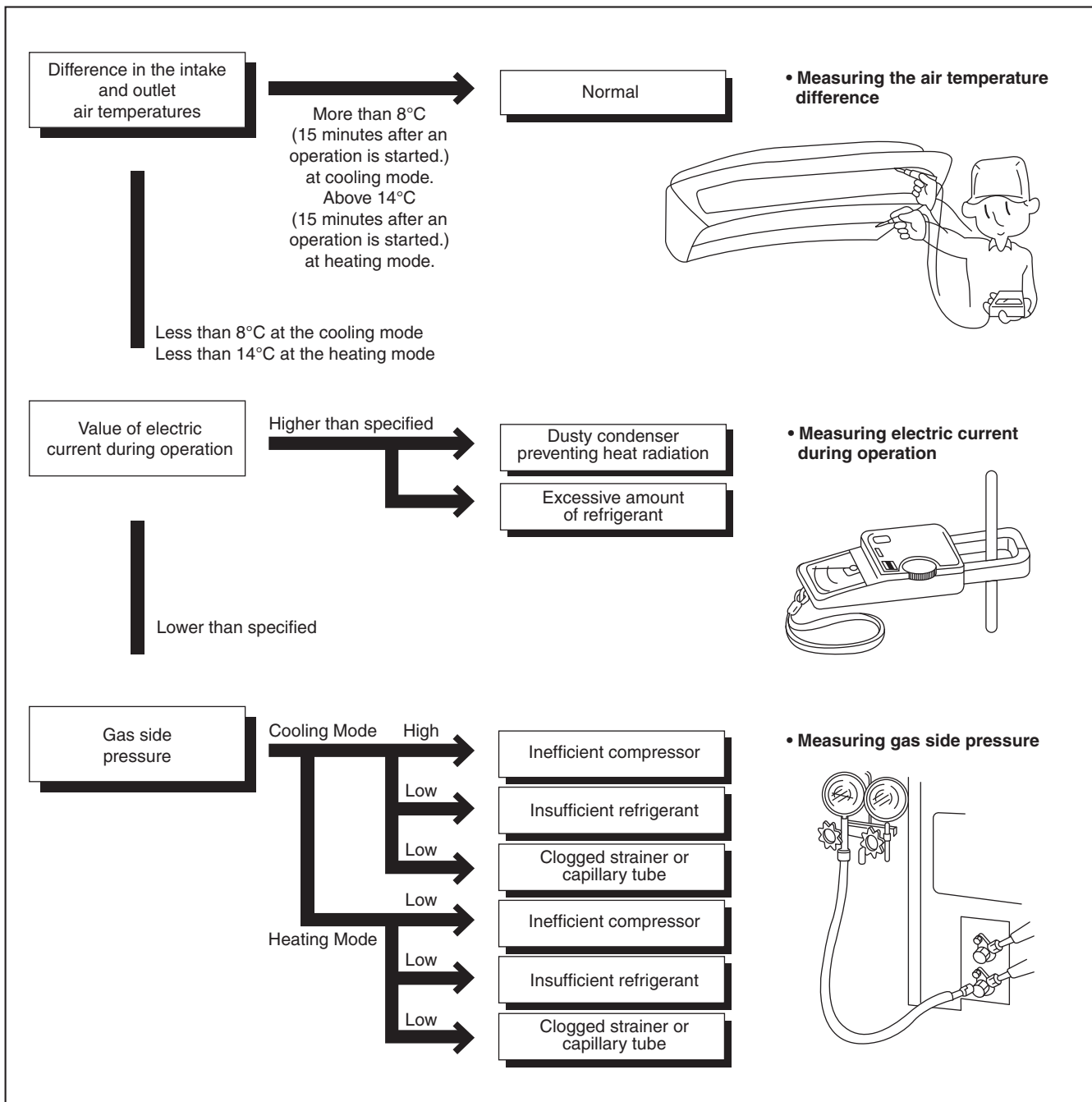

## 15.2 Relationship Between the Condition of the Air Conditioner and Pressure and Electric Current

Condition of the air conditioner	Cooling Mode			Heating Mode		
	Low Pressure	High Pressure	Electric current during operation	Low Pressure	High Pressure	Electric current during operation
Insufficient refrigerant (gas leakage)	↘	↘	↘	↘	↘	↘
Clogged capillary tube or Strainer	↘	↘	↘	↗	↗	↗
Short circuit in the indoor unit	↘	↘	↘	↗	↗	↗
Heat radiation deficiency of the outdoor unit	↗	↗	↗	↘	↘	↘
Inefficient compression	↗	↘	↘	↗	↘	↘

- Carry out the measurement of pressure, electric current, and temperature fifteen minutes after an operation is started.

## 15.3 Breakdown Self Diagnosis Function

### 15.3.1 Self Diagnosis Function (Three Digits Alphanumeric Code)

- Once abnormality has occurred during operation, the unit will stop its operation, and OFF/ON operation LED OFF.
- OFF indicator does not shown on remote control display.
- In operation after breakdown repair, the last error code abnormality will be stored in EEPROM.
- **To make a diagnosis**
  - 1 OFF/ON operation LED OFF and the unit automatically stops the operation, but the OFF indicator does not shown.
  - 2 Press CHECK button continuously for 5 seconds.
  - 3 “- -” will be displayed on the remote controller display.
  - 4 Press timer ▲ or ▼ button on the remote control. The error code “H00” (no abnormality) will be displayed.
  - 5 Every press of the button (▲ or ▼) will increase the error code number.
  - 6 When the displayed error code matches the unit's error code, OFF/ON operation LED will be ON continuously.
  - 7 The breakdown diagnosis mode will be cancelled by pressing CHECK button continuously for 5 seconds or wait for 30 seconds.

- **AC Reset button**

When AC Reset button is pressed, the error code will be reset so that the unit will be able to operate and recheck if any error occurred.

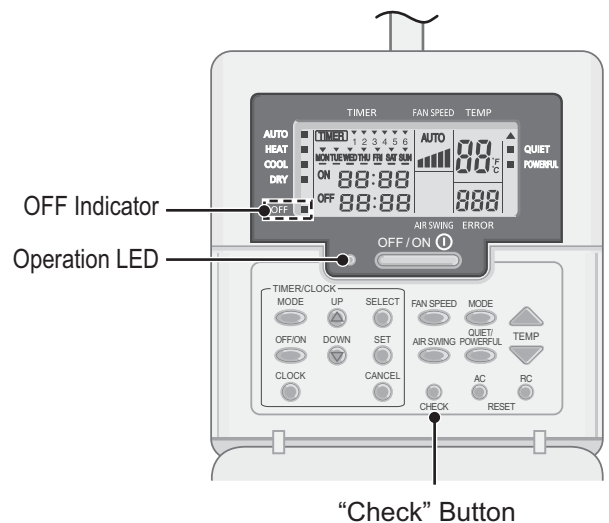

- **To display memorized error status:**

- 1 Turn ON the power supply.
- 2 Press CHECK button continuously for 5 seconds.
- 3 “- -” will be displayed on the remote controller display.
- 4 Press timer ▲ or ▼ button on the remote control. The error code "H00" (no abnormality) will be displayed.
- 5 Every press of the button (▲ or ▼) will increase the error code number.
- 6 When the displayed error code matches the unit's error code, OFF/ON operation LED will be ON continuously.
- 7 The breakdown diagnosis mode will be cancelled by pressing CHECK button continuously for 5 seconds or wait for 30 seconds.

## 15.4 Error Codes Table

Diagnosis display	Abnormality / Protection control	Abnormality Judgment	Emergency Operation	Primary location to verify
H00	No abnormality detected	—	Normal operation	—
H11	Indoor / outdoor abnormal communication	> 1 min. after starting operation	Indoor fan operation only	<ul style="list-style-type: none"> <li>• Internal / external cable connections</li> <li>• Indoor / Outdoor PCB</li> </ul>
H12	Connection capability rank abnormal	—	—	—
H14	Indoor intake air temperature sensor abnormality	Continue for 5 sec.	—	<ul style="list-style-type: none"> <li>• Intake air temperature sensor (defective or disconnected)</li> </ul>
H15	Outdoor compressor temperature sensor abnormality	Continue for 5 sec.	—	<ul style="list-style-type: none"> <li>• Compressor temperature sensor (defective or disconnected)</li> </ul>
H16	Outdoor Current Transformer open circuit	—	—	<ul style="list-style-type: none"> <li>• Outdoor PCB</li> <li>• IPM (Power transistor) module</li> </ul>
H19	Indoor fan motor mechanism lock	—	—	<ul style="list-style-type: none"> <li>• Indoor PCB</li> <li>• Fan motor</li> </ul>
H21	Indoor float switch operation abnormal	—	—	—
H23	Indoor heat exchanger temperature sensor 1 abnormality	Continue for 5 sec.	O (Cooling only)	<ul style="list-style-type: none"> <li>• Heat exchanger temperature sensor 1 (defective or disconnected)</li> </ul>
H24	Indoor heat exchanger temperature sensor 2 abnormality	Continue for 5 sec.	—	<ul style="list-style-type: none"> <li>• Heat exchanger temperature sensor 2 (defective or disconnected)</li> </ul>
H27	Outdoor air temperature sensor abnormality	Continue for 5 sec.	O	<ul style="list-style-type: none"> <li>• Outdoor temperature sensor (defective or disconnected)</li> </ul>
H28	Outdoor heat exchanger temperature sensor abnormality	Continue for 5 sec.	O	<ul style="list-style-type: none"> <li>• Outdoor heat exchanger temperature sensor (defective or disconnected)</li> </ul>
H30	Discharge temperature sensor abnormality	Continue for 5 sec.	—	<ul style="list-style-type: none"> <li>• Discharge temperature sensor</li> </ul>
H32	Outdoor heat exchanger temperature sensor 2 abnormality	Continue for 5 sec.	—	<ul style="list-style-type: none"> <li>• Discharge pipe temperature sensor (defective or disconnected).</li> </ul>
H34	Outdoor heat sink temperature sensor abnormality	Continue for 2 sec.	—	<ul style="list-style-type: none"> <li>• Outdoor heat sink temperature sensor (defective or disconnected).</li> </ul>
H35	Indoor drain water adverse current abnormal	—	—	—
H36	Gas pipe temperature sensor abnormality	Continue for 5 sec.	—	<ul style="list-style-type: none"> <li>• Gas pipe temperature sensor (defective or disconnected).</li> </ul>
H37	Outdoor liquid pipe temperature sensor abnormality	Continue for 2 sec.	—	<ul style="list-style-type: none"> <li>• Outdoor liquid pipe temperature sensor (defective or disconnected).</li> </ul>
H39	Abnormal indoor operating unit or standby units	—	—	—
H41	Wiring or piping connection abnormality	3 minutes after compressor start up	—	—
H97	Outdoor Fan Motor lock abnormality	2 times occurrence within 30 minutes	—	<ul style="list-style-type: none"> <li>• Outdoor PCB</li> <li>• Outdoor Fan Motor</li> </ul>
H98	Indoor high pressure protection	—	—	<ul style="list-style-type: none"> <li>• Air filter dirty</li> <li>• Air circulation short circuit</li> </ul>
H99	Indoor heat exchanger anti-freezing protection	—	—	<ul style="list-style-type: none"> <li>• Insufficient refrigerant</li> <li>• Air filter dirty</li> </ul>
F11	Cooling / Heating cycle changeover abnormality	4 times occurrence within 30 minutes	—	<ul style="list-style-type: none"> <li>• 4-way valve</li> <li>• V-coil</li> </ul>
F17	Indoor unit freezing error	3 times occurrence within 30 minutes	—	<ul style="list-style-type: none"> <li>• Expansion valve leakage</li> <li>• Indoor unit pipe temperature sensor (check for changes in characteristics and check its resistance)</li> </ul>
F90	PFC control	4 times occurrence within 10 minutes	—	<ul style="list-style-type: none"> <li>• Voltage at PFC</li> </ul>
F91	Refrigeration cycle abnormality	2 times occurrence within 20 minutes	—	<ul style="list-style-type: none"> <li>• No refrigerant (3-way valve is closed)</li> </ul>
F93	Outdoor compressor abnormal revolution	4 times occurrence within 20 minutes	—	<ul style="list-style-type: none"> <li>• Outdoor compressor</li> </ul>
F95	Cool high pressure protection	4 times occurrence within 20 minutes	—	<ul style="list-style-type: none"> <li>• Outdoor refrigerant circuit</li> </ul>
F96	IPM (power transistor) overheating protection	—	—	<ul style="list-style-type: none"> <li>• Excess refrigerant</li> <li>• Improper heat radiation</li> <li>• IPM (Power transistor)</li> </ul>
F97	Outdoor compressor overheating protection	4 times occurrence within 20 minutes	—	<ul style="list-style-type: none"> <li>• Insufficient refrigerant</li> <li>• Compressor</li> </ul>



Diagnosis display	Abnormality / Protection control	Abnormality Judgment	Emergency Operation	Primary location to verify
F98	Total running current protection	3 times occurrence within 20 minutes	—	<ul style="list-style-type: none"> <li>• Excess refrigerant</li> <li>• Improper heat radiation</li> </ul>
F99	Outdoor Direct Current (DC) peak detection	7 times occurrence continuously	—	<ul style="list-style-type: none"> <li>• Outdoor PCB</li> <li>• IPM (Power transistor)</li> <li>• Compressor</li> </ul>

Note:

“O” - Frequency measured and fan speed fixed.

The memory data of error code is erased when the power supply is cut off, or press the Auto Switch until “beep” sound heard following by pressing the “CHECK” button at Remote Control.

Although operation forced to stop when abnormality detected, emergency operation is possible for certain errors (refer to Error Codes Table) by using Remote Control or Auto Switch at indoor unit. However, the Remote Control signal receiving sound is changed from one “beep” to four “beep” sounds.

## 15.5 Self-diagnosis Method

### 15.5.1 H11 (Indoor/Outdoor Abnormal Communication)

#### Malfunction Decision Conditions

- During startup and operation of cooling and heating, the data received from outdoor unit in indoor unit signal transmission is checked whether it is normal.

#### Malfunction Caused

- Faulty indoor unit PCB.
- Faulty outdoor unit PCB.
- Indoor unit-outdoor unit signal transmission error due to wiring error.
- Indoor unit-outdoor unit signal transmission error due to breaking of wire in the connection wires between the indoor and outdoor units.

#### Troubleshooting

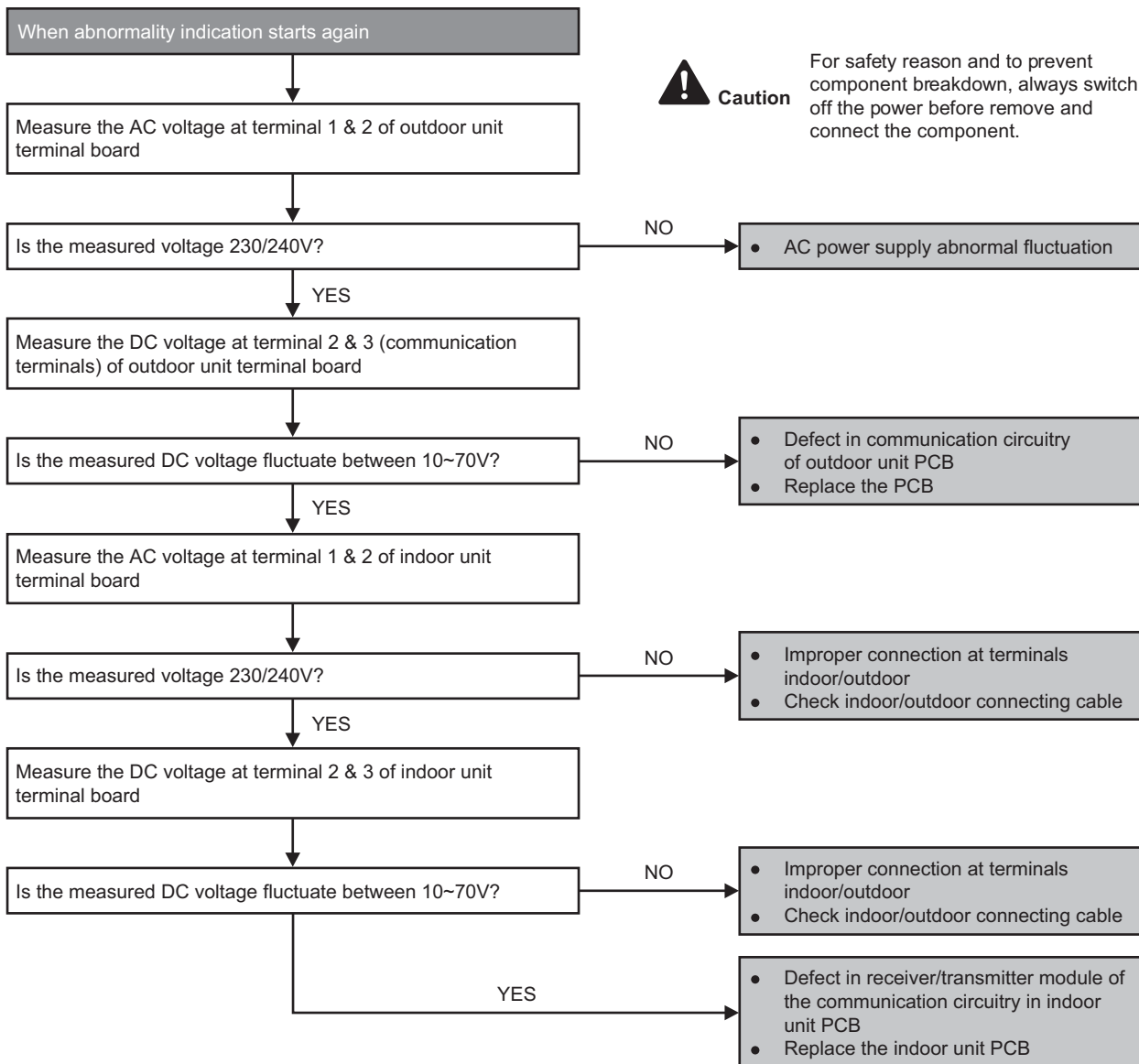

## 15.5.2 H12 (Indoor/Outdoor Capacity Rank Mismatched)

### Malfunction Decision Conditions

- During startup, error code appears when different types of indoor and outdoor units are interconnected.

### Malfunction Caused

- Wrong models interconnected.
- Wrong indoor unit or outdoor unit PCBs mounted.
- Indoor unit or outdoor unit PCBs defective.
- Indoor-outdoor unit signal transmission error due to wrong wiring.
- Indoor-outdoor unit signal transmission error due to breaking of wire 3 in the connection wires between the indoor and outdoor units.

### Troubleshooting

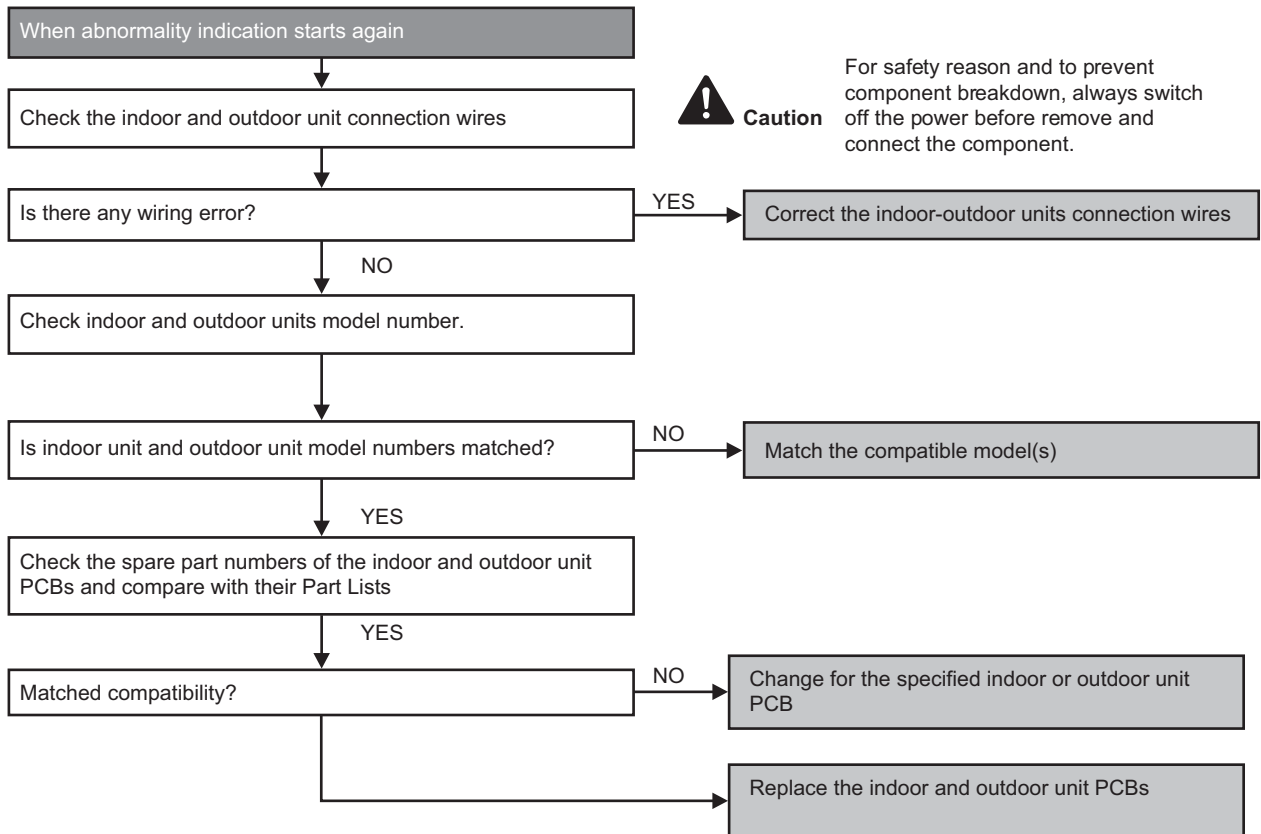

### 15.5.3 H14 (Indoor Intake Air Temperature Sensor Abnormality)

#### Malfunction Decision Conditions

- During startup and operation of cooling and heating, the temperatures detected by the indoor intake air temperature sensor are used to determine sensor errors.

#### Malfunction Caused

- Faulty connector connection.
- Faulty sensor.
- Faulty PCB.

#### Troubleshooting

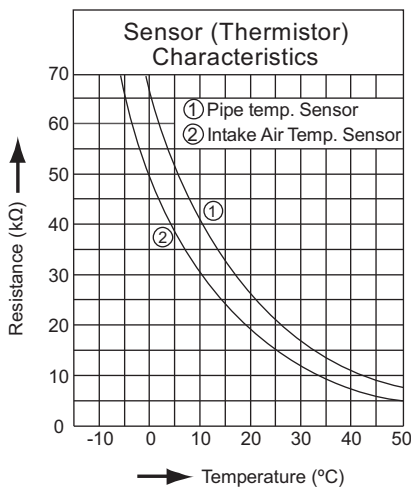
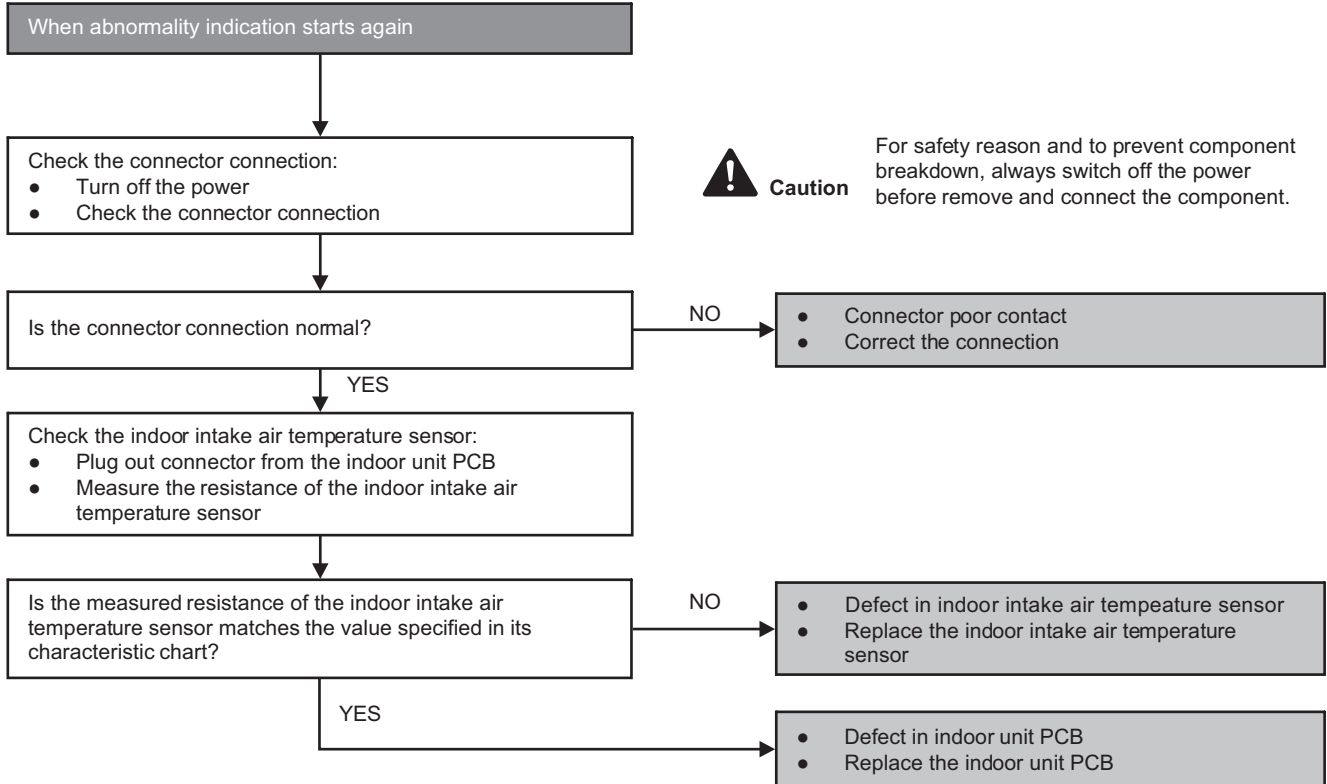

## 15.5.4 H15 (Compressor Temperature Sensor Abnormality)

### Malfunction Decision Conditions

- During startup and operation of cooling and heating, the temperatures detected by the outdoor compressor temperature sensor are used to determine sensor errors.

### Malfunction Caused

- Faulty connector connection.
- Faulty sensor.
- Faulty PCB.

### Troubleshooting

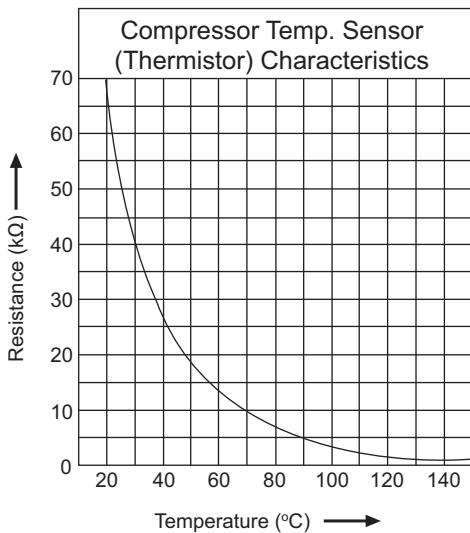
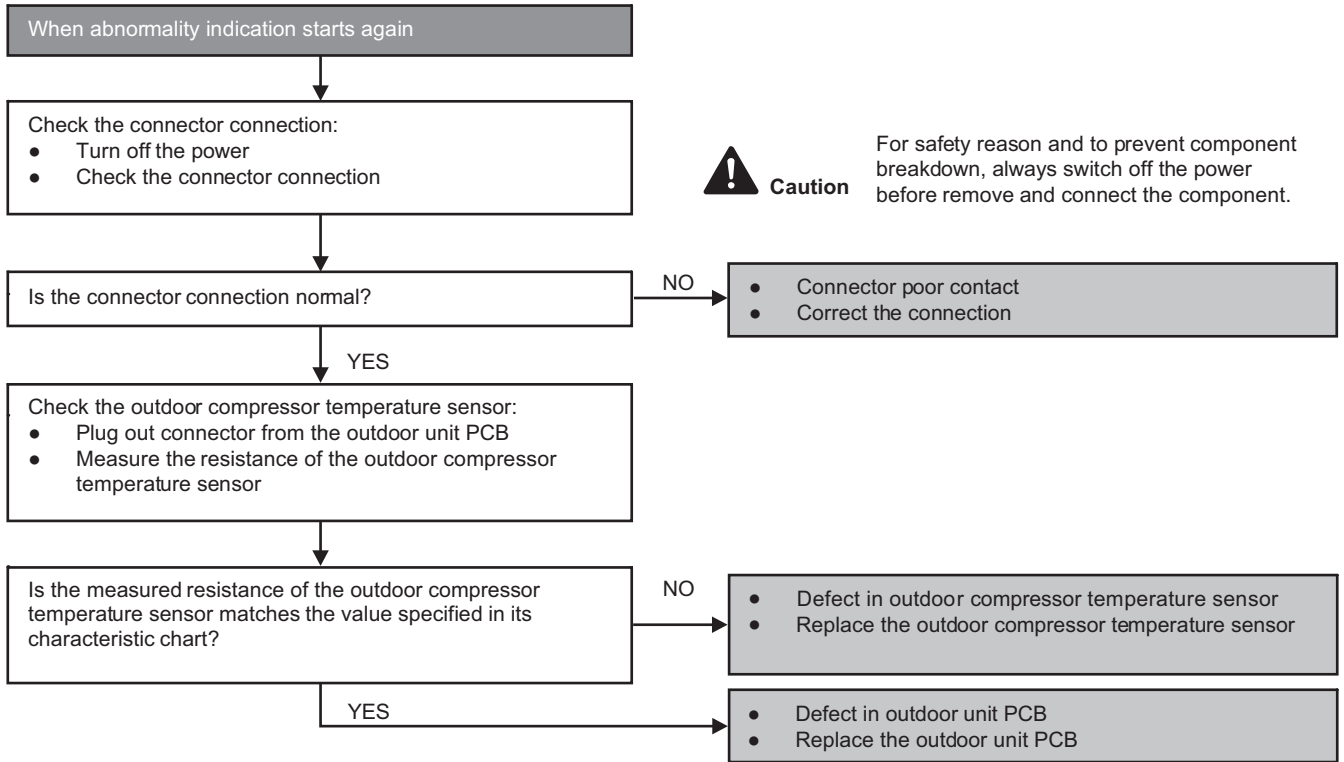

## 15.5.5 H16 (Outdoor Current Transformer)

### Malfunction Decision Conditions

- An input current, detected by Current Transformer CT, is below threshold value when the compressor is operating at certain frequency value for 3 minutes.

### Malfunction Caused

- Lack of gas
- Broken CT (current transformer)
- Broken Outdoor PCB

### Troubleshooting

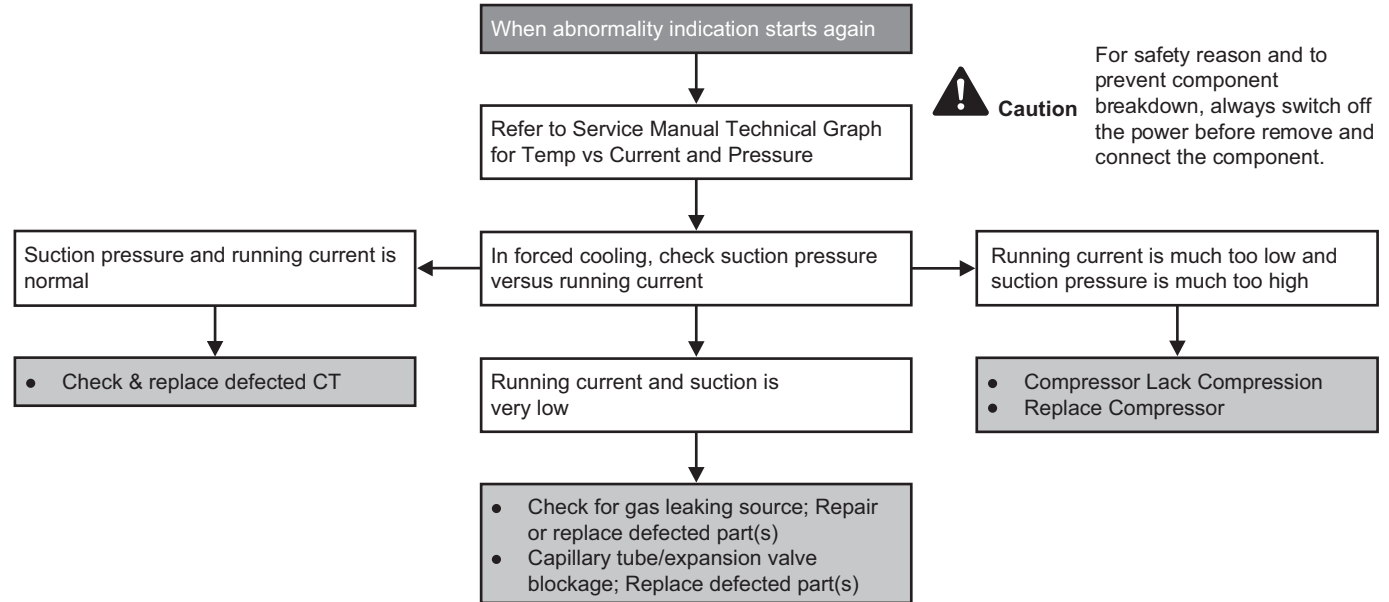

## 15.5.6 H19 (Indoor Fan Motor – DC Motor Mechanism Locked)

### Malfunction Decision Conditions

- The rotation speed detected by the Hall IC during fan motor operation is used to determine abnormal fan motor (feedback of rotation > 2550 rpm or < 50 rpm)

### Malfunction Caused

- Operation stops due to short circuit inside the fan motor winding.
- Operation stops due to breaking of wire inside the fan motor.
- Operation stops due to breaking of fan motor lead wires.
- Operation stops due to Hall IC malfunction.
- Operation error due to faulty indoor unit PCB.

### Troubleshooting

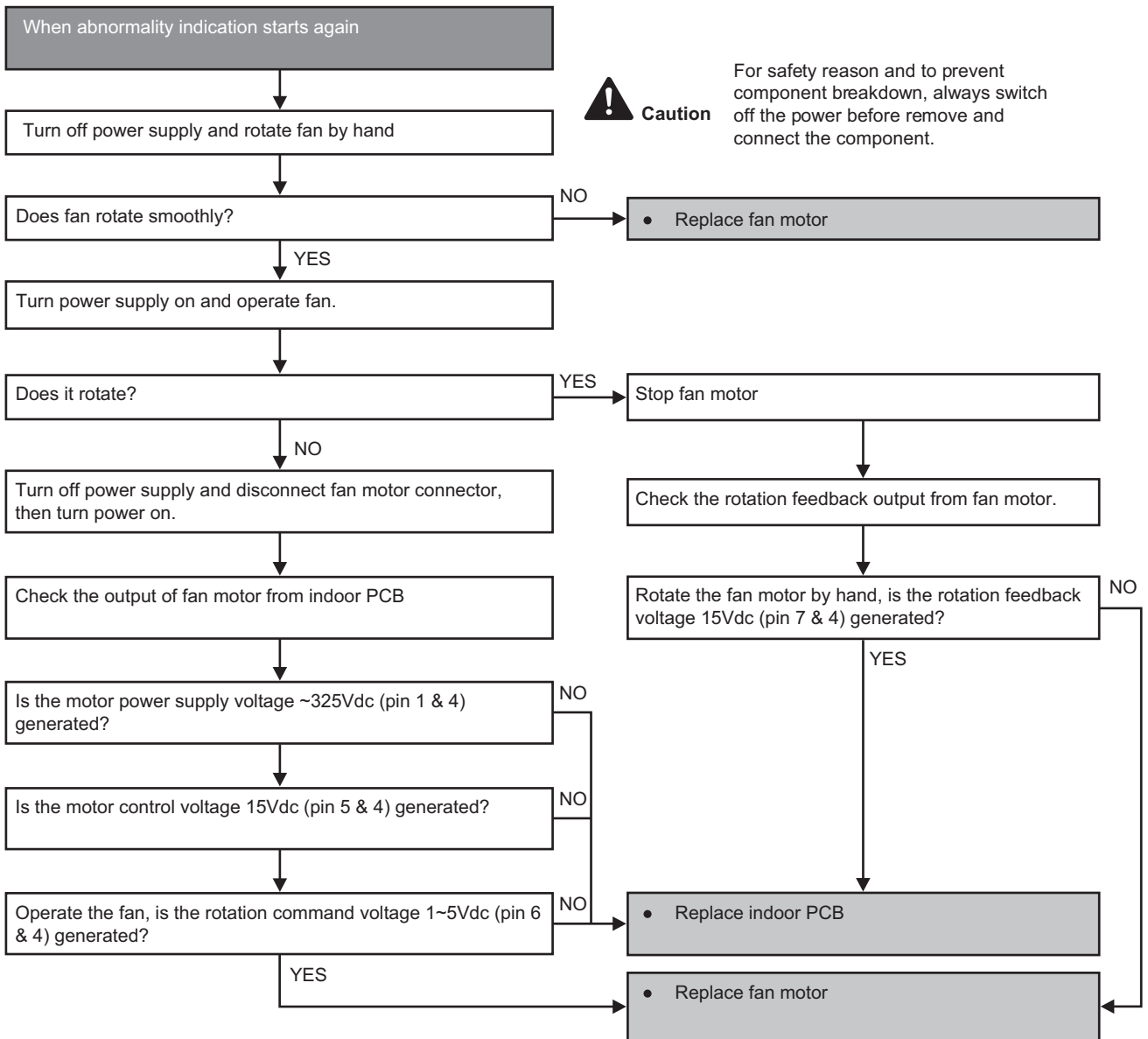

## 15.5.7 H23 (Indoor Pipe Temperature Sensor Abnormality)

### Malfunction Decision Conditions

- During startup and operation of cooling and heating, the temperatures detected by the indoor heat exchanger temperature sensor are used to determine sensor errors.

### Malfunction Caused

- Faulty connector connection.
- Faulty sensor.
- Faulty PCB.

### Troubleshooting

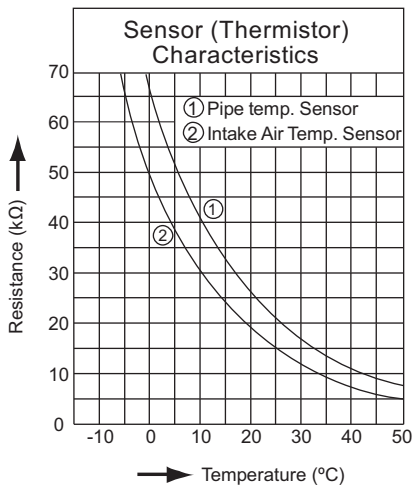
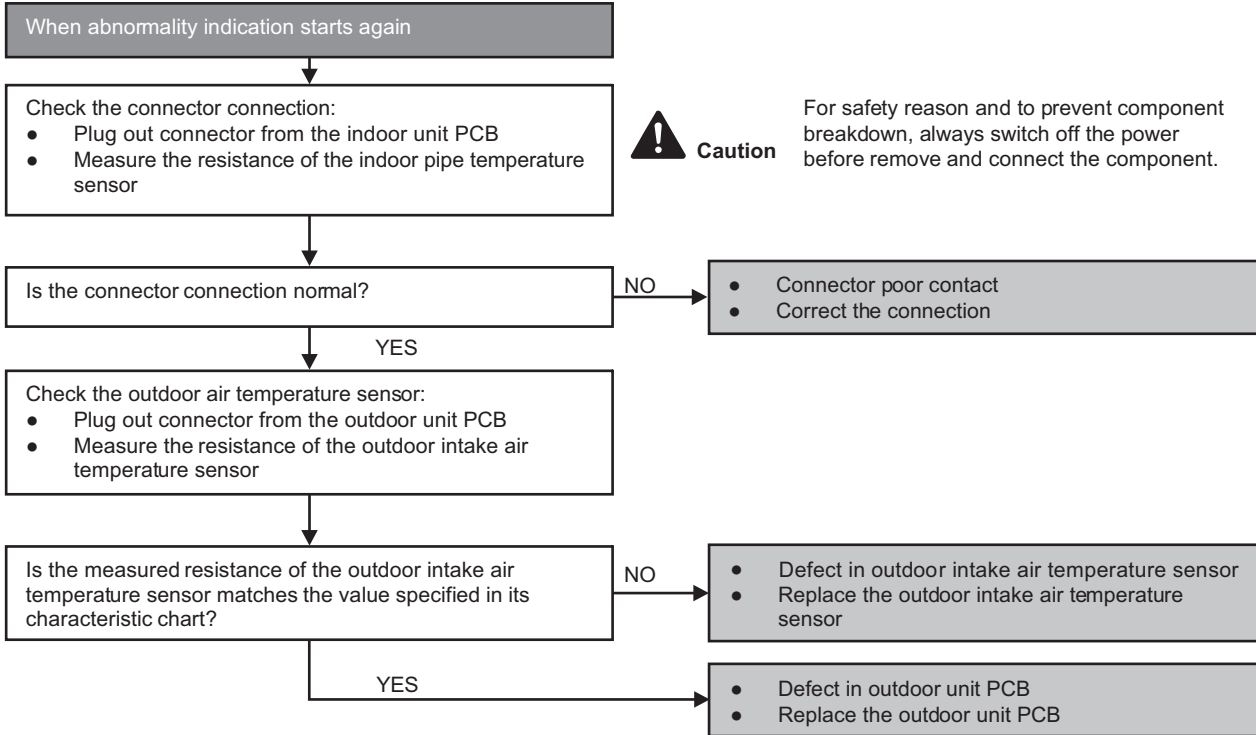



## 15.5.8 H24 (Indoor Pipe Temperature Sensor 2 Abnormality)

### Malfunction Decision Conditions

- During startup and operation of cooling and heating, the temperatures detected by the indoor heat exchanger temperature sensor 2 are used to determine sensor errors.

### Malfunction Caused

- Faulty connector connection.
- Faulty sensor.
- Faulty PCB.

### Troubleshooting

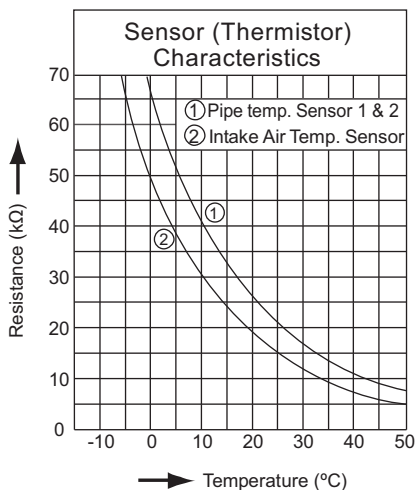
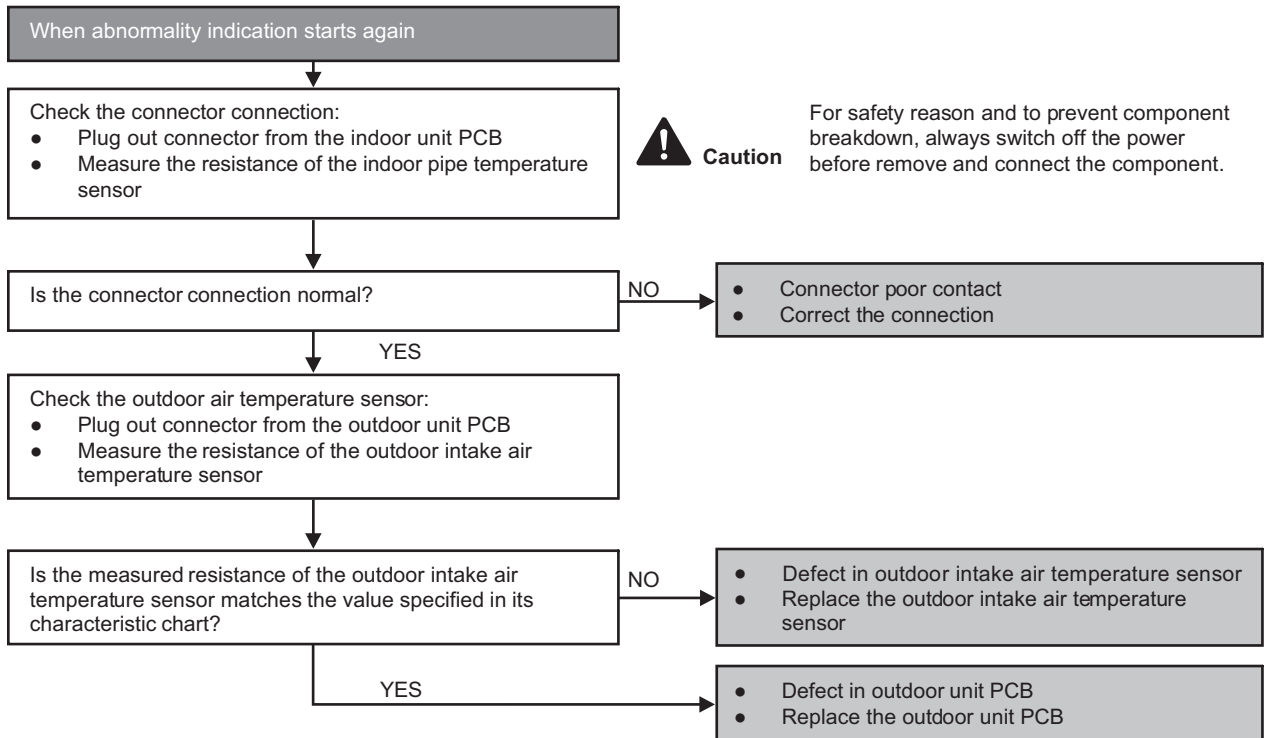

## 15.5.9 H27 (Outdoor Air Temperature Sensor Abnormality)

### Malfunction Decision Conditions

- During startup and operation of cooling and heating, the temperatures detected by the outdoor air temperature sensor are used to determine sensor errors.

### Malfunction Caused

- Faulty connector connection.
- Faulty sensor.
- Faulty PCB.

### Troubleshooting

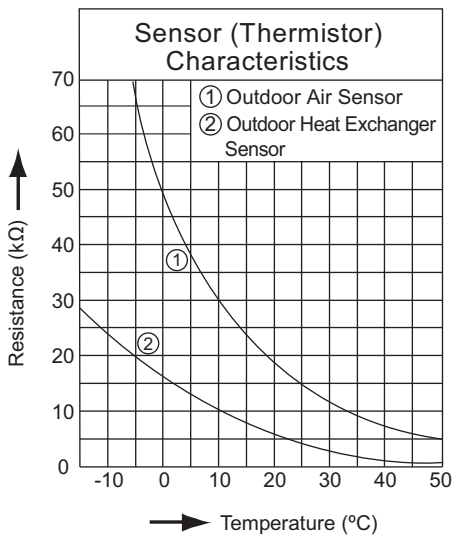
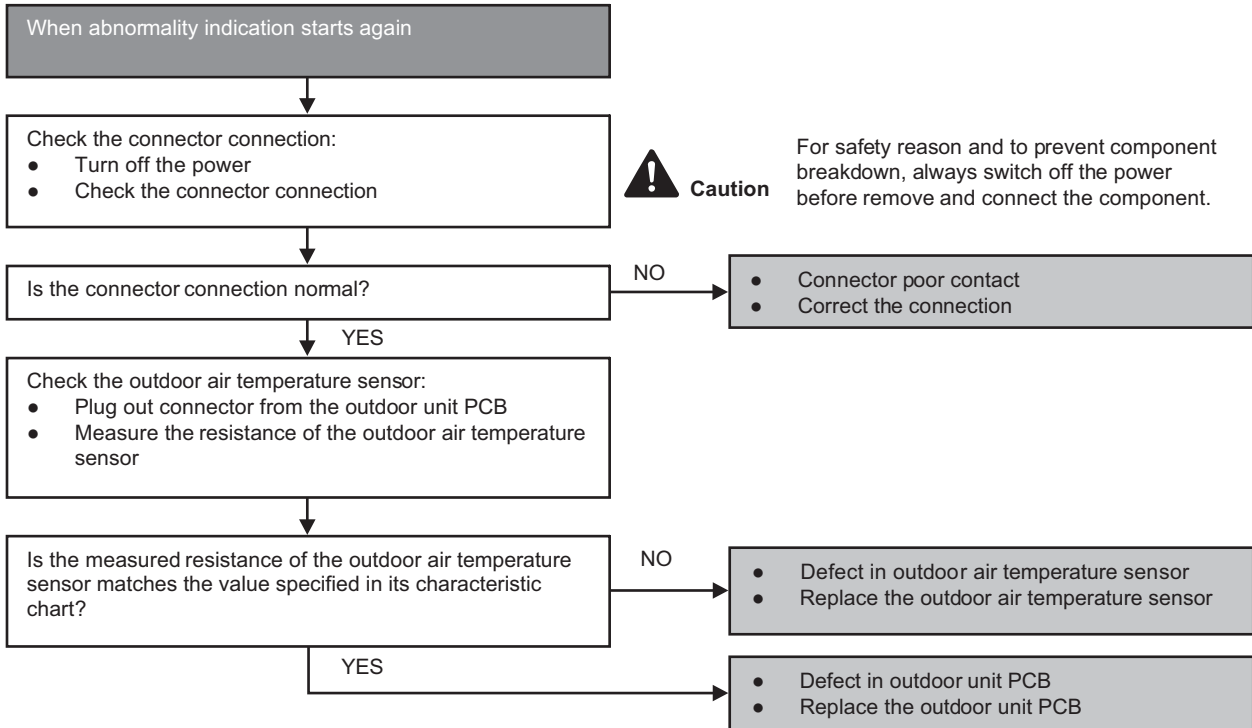

## 15.5.10 H28 (Outdoor Pipe Temperature Sensor Abnormality)

### Malfunction Decision Conditions

- During startup and operation of cooling and heating, the temperatures detected by the outdoor pipe temperature sensor are used to determine sensor errors.

### Malfunction Caused

- Faulty connector connection.
- Faulty sensor.
- Faulty PCB.

### Troubleshooting

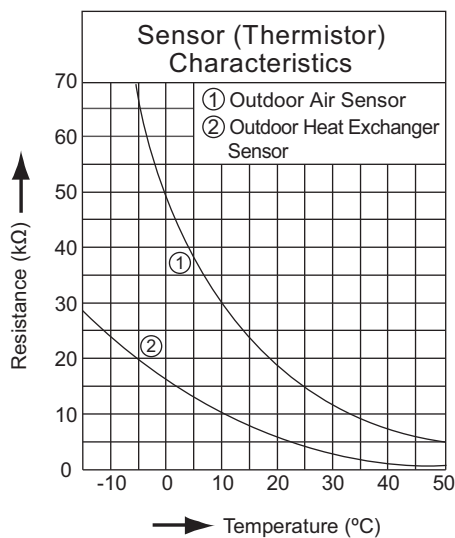
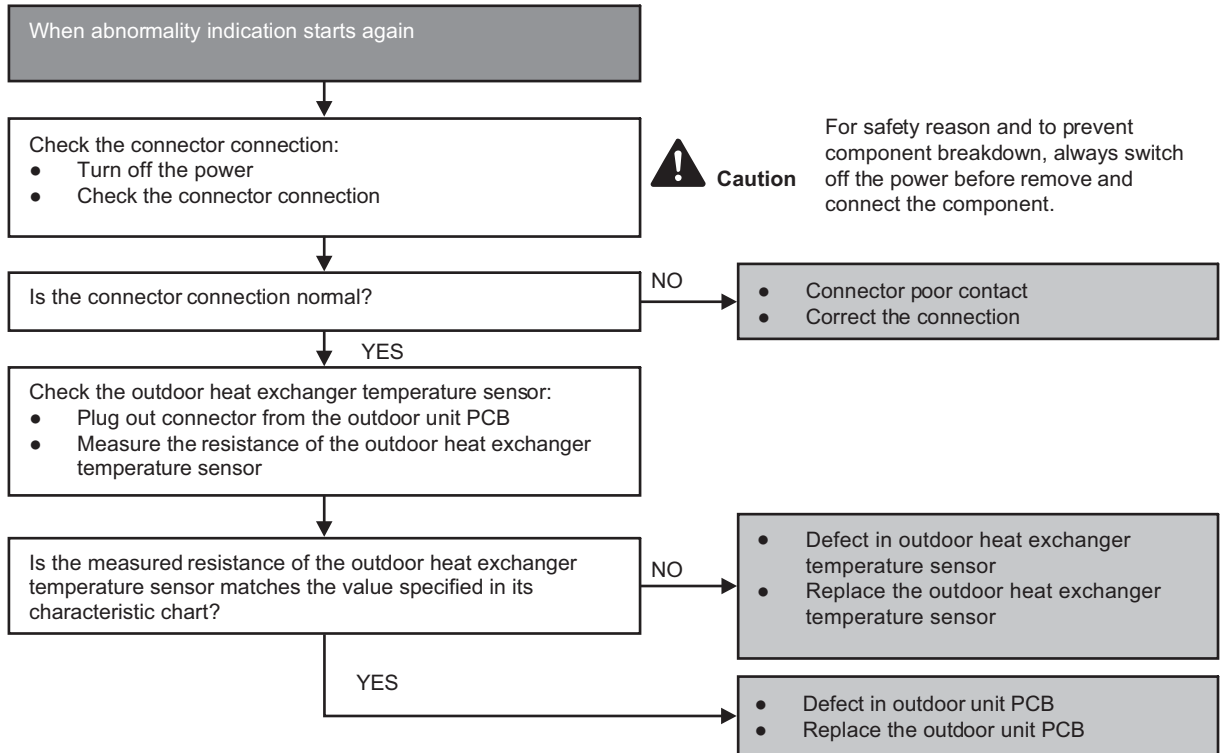

## 15.5.11 H30 (Compressor Discharge Temperature Sensor Abnormality)

### Malfunction Decision Conditions

- During startup and operation of cooling and heating, the temperatures detected by the outdoor discharge pipe temperature sensor are used to determine sensor errors.

### Malfunction Caused

- Faulty connector connection.
- Faulty sensor.
- Faulty PCB.

### Troubleshooting

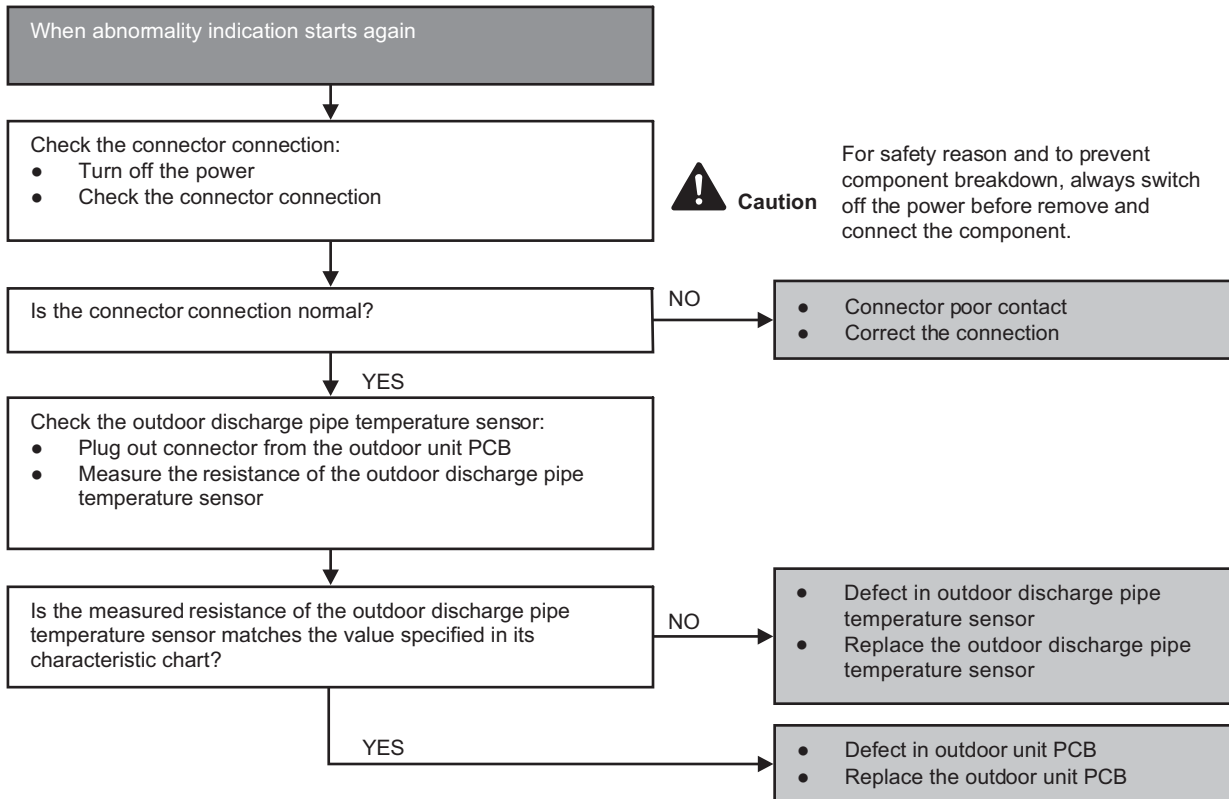

### 15.5.12 H33 (Unspecified Voltage between Indoor and Outdoor)

#### Malfunction Decision Conditions

- The supply power is detected for its requirement by the indoor/outdoor transmission.

#### Malfunction Caused

- Wrong models interconnected.
- Wrong indoor unit and outdoor unit PCBs used.
- Indoor unit or outdoor unit PCB defective.

#### Troubleshooting

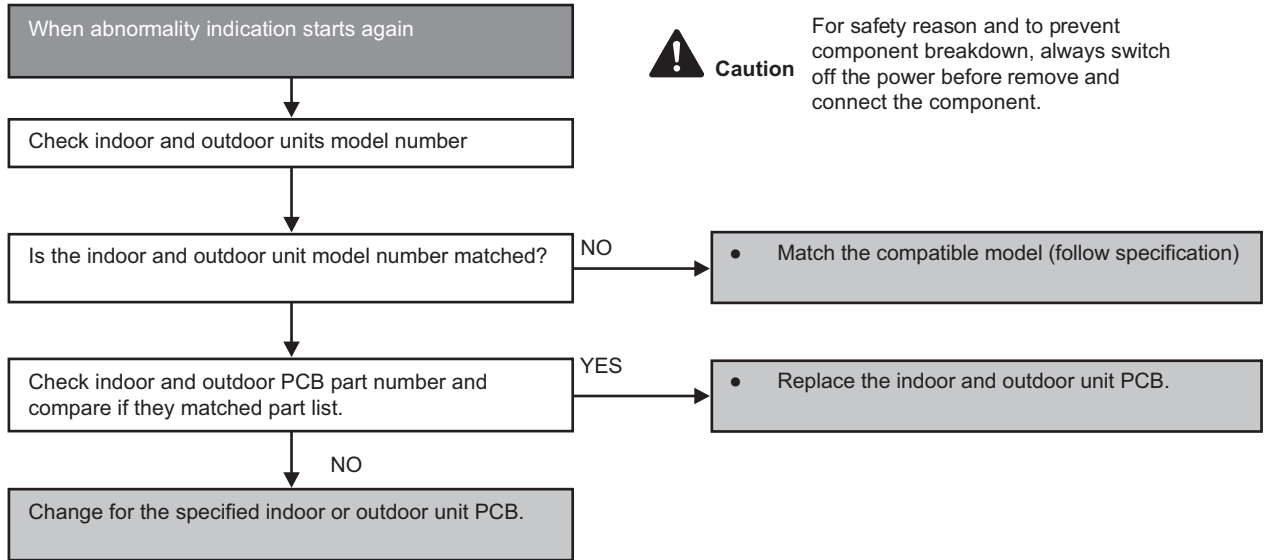

### 15.5.13 H97 (Outdoor Fan Motor – DC Motor Mechanism Locked)

#### Malfunction Decision Conditions

- The rotation speed detected by the Hall IC during fan motor operation is used to determine abnormal fan motor.

#### Malfunction Caused

- Operation stops due to short circuit inside the fan motor winding.
- Operation stops due to breaking of wire inside the fan motor.
- Operation stops due to breaking of fan motor lead wires.
- Operation stops due to Hall IC malfunction.
- Operation error due to faulty outdoor unit PCB.

#### Troubleshooting

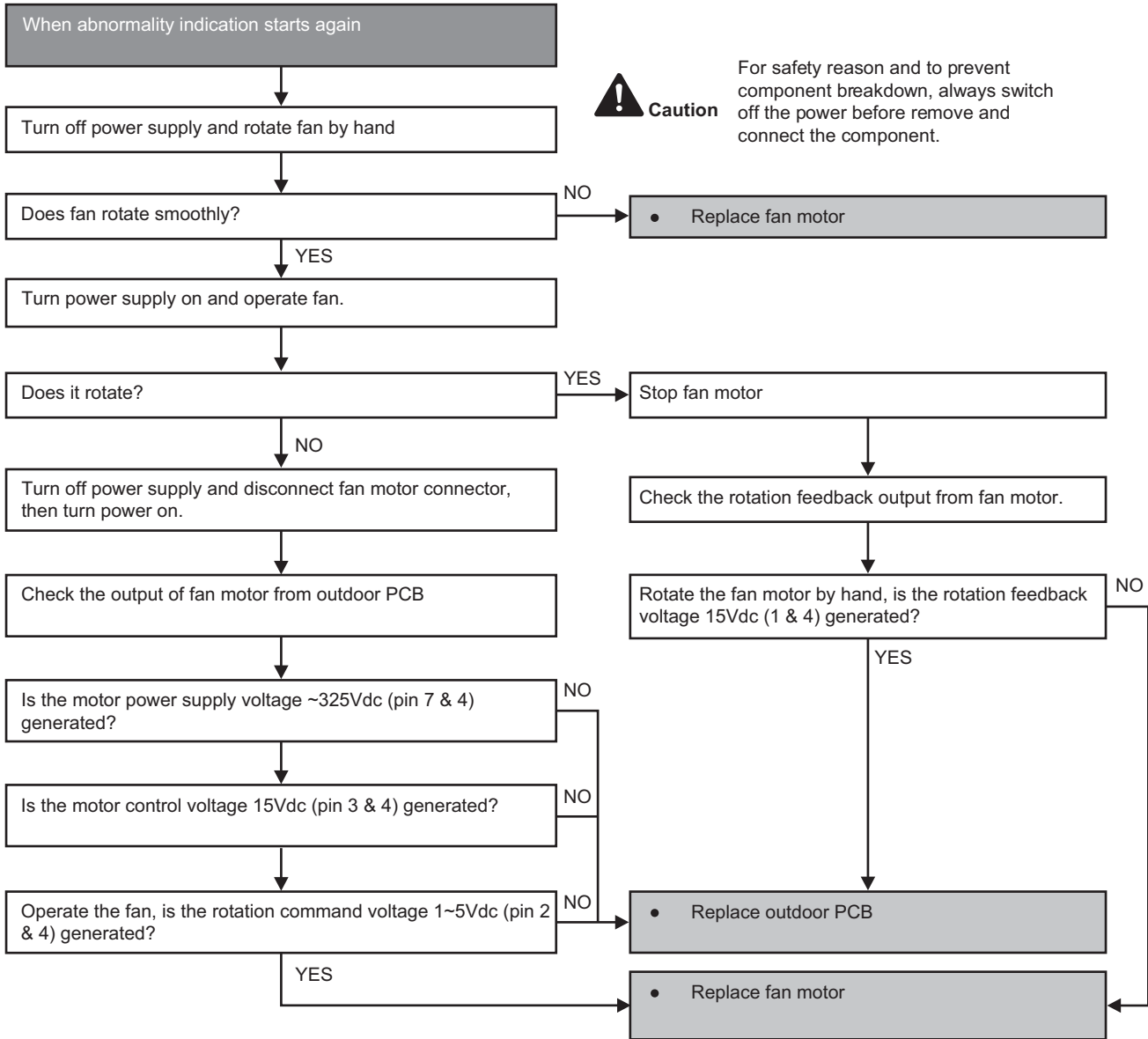

## 15.5.14 H98 (Error Code Stored in Memory and no alarm is triggered / no TIMER LED flashing)

### Malfunction Decision Conditions

- Indoor high pressure is detected when indoor heat exchanger is detecting very high temperature when the unit is operating in heating operation.
- Phenomena: unit is stopping and re-starting very often in heating mode.

### Malfunction Caused

- Indoor heat exchanger thermistor
- Clogged air filter or heat exchanger
- Over-bent pipe (liquid side)

### Troubleshooting

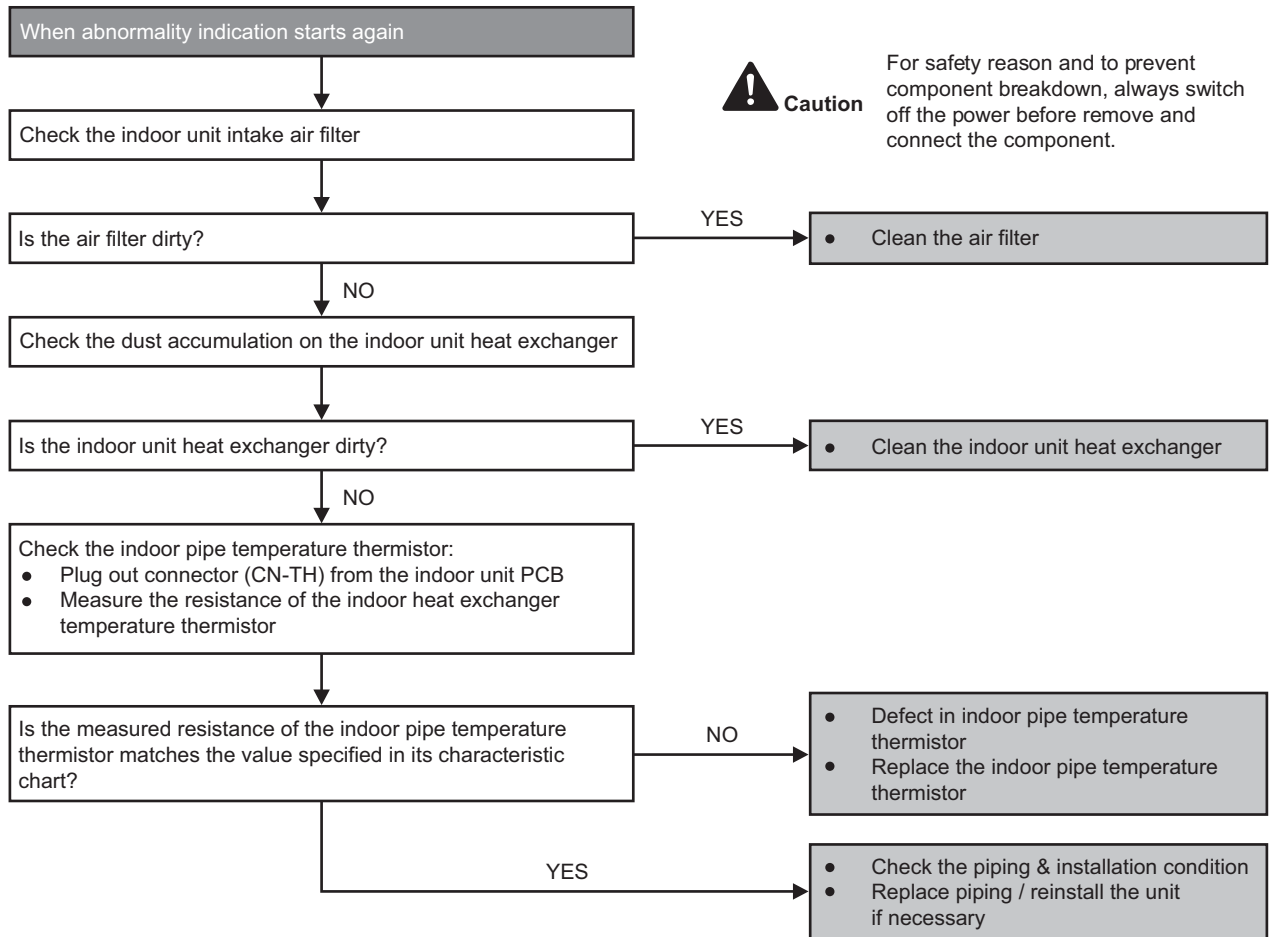

## 15.5.15 H99 (Indoor Freeze Prevention Protection: Cooling or Soft Dry)

Error Code will not display (no Timer LED blinking) but store in EEPROM

### Malfunction Decision Conditions

- Freeze prevention control takes place (when indoor pipe temperature is lower than 2°C)

### Malfunction Caused

- Air short circuit at indoor unit
- Clogged indoor unit air filter
- Dust accumulation on the indoor unit heat exchanger
- 2/3 way valve closed
- Faulty indoor unit fan motor
- Refrigerant shortage (refrigerant leakage)
- Clogged expansion valve or strainer
- Faulty indoor pipe temperature sensor
- Faulty indoor unit PCB

### Troubleshooting

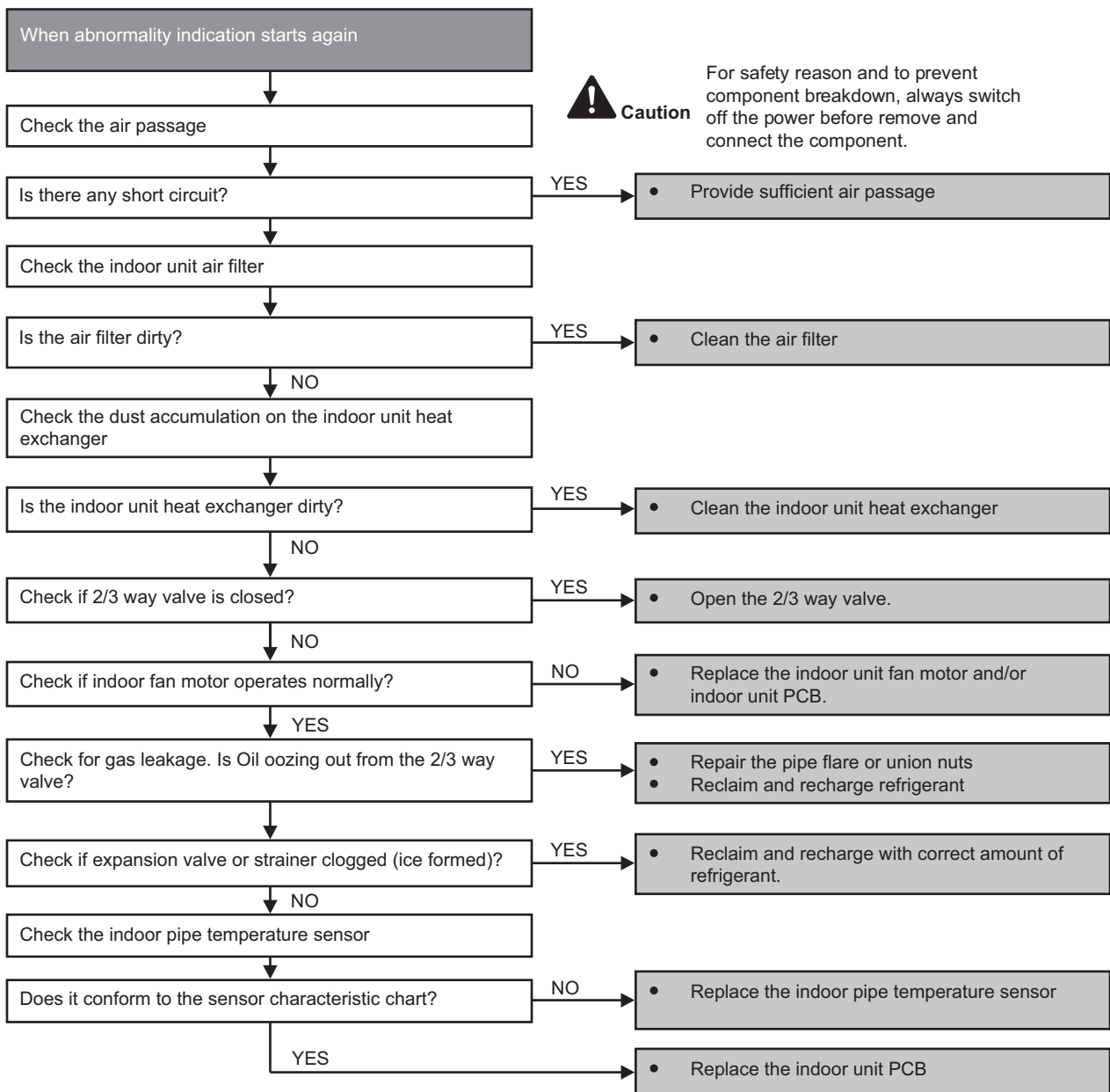



## 15.5.16 F11 (4-way Valve Switching Failure)

### Malfunction Decision Conditions

- When indoor heat exchanger is cold during heating (except deice) or when indoor heat exchanger is hot during cooling and compressor operating, the 4-way valve is detected as malfunction.

### Malfunction Caused

- Indoor heat exchanger (pipe) thermistor
- 4-way valve malfunction

### Troubleshooting

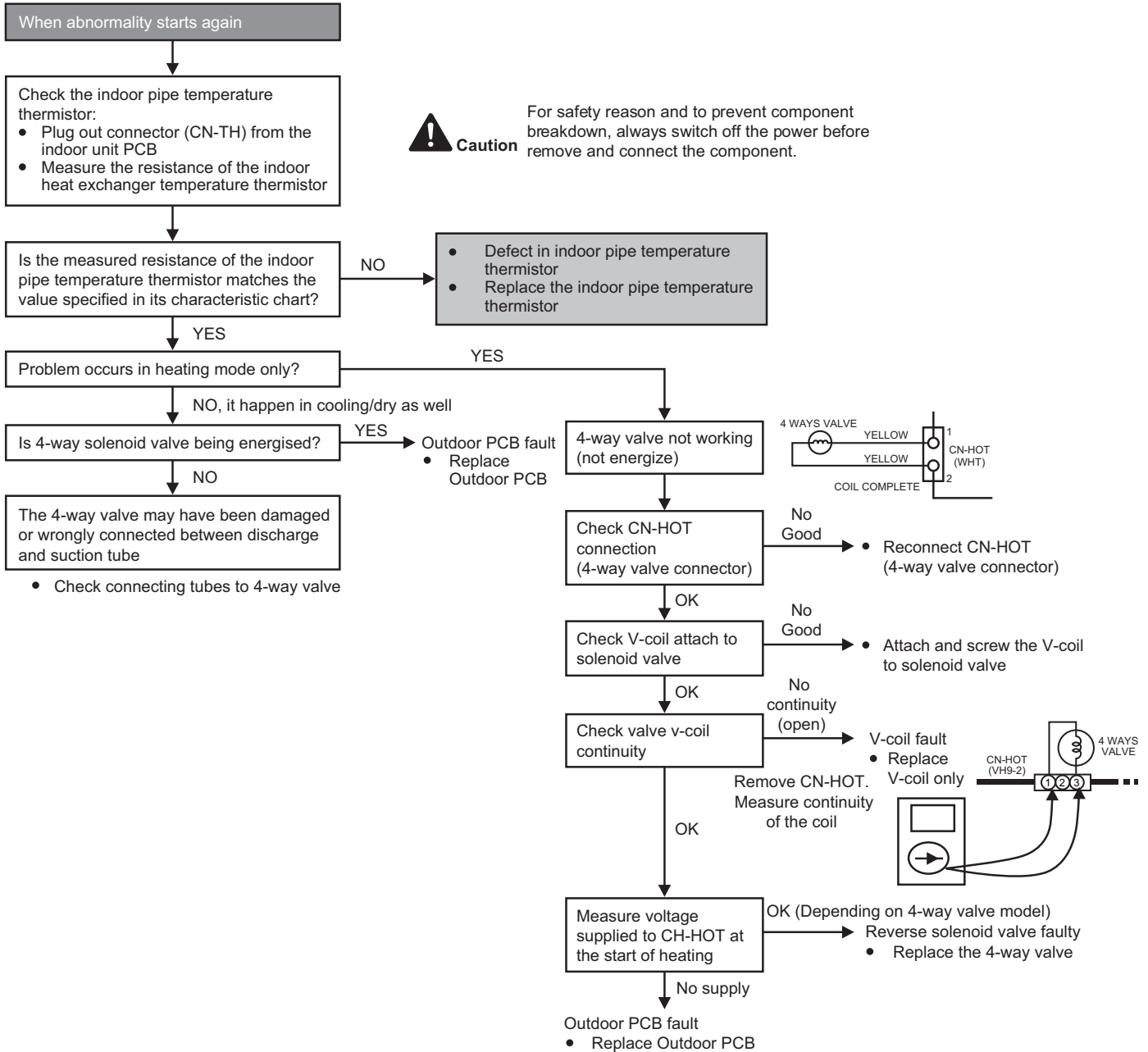

\* Check gas side pipe – for hot gas flow in cooling mode

## 15.5.17 F90 (Power Factor Correction Protection)

### Malfunction Decision Conditions

- To maintain DC voltage level supply to power transistor.
- To detect high DC voltage level after rectification.

### Malfunction Caused

- During startup and operation of cooling and heating, when Power Factor Correction (PFC) protection circuitry at the outdoor unit main PCB senses abnormal DC voltage level for power transistors.
- When DC voltage detected is LOW, transistor switching will turn ON by controller to push-up the DC level.
- When DC voltage detected is HIGH (391Vdc – 425Vdc), active LOW signal will send by the controller to turn OFF relay RY-C.

### Troubleshooting

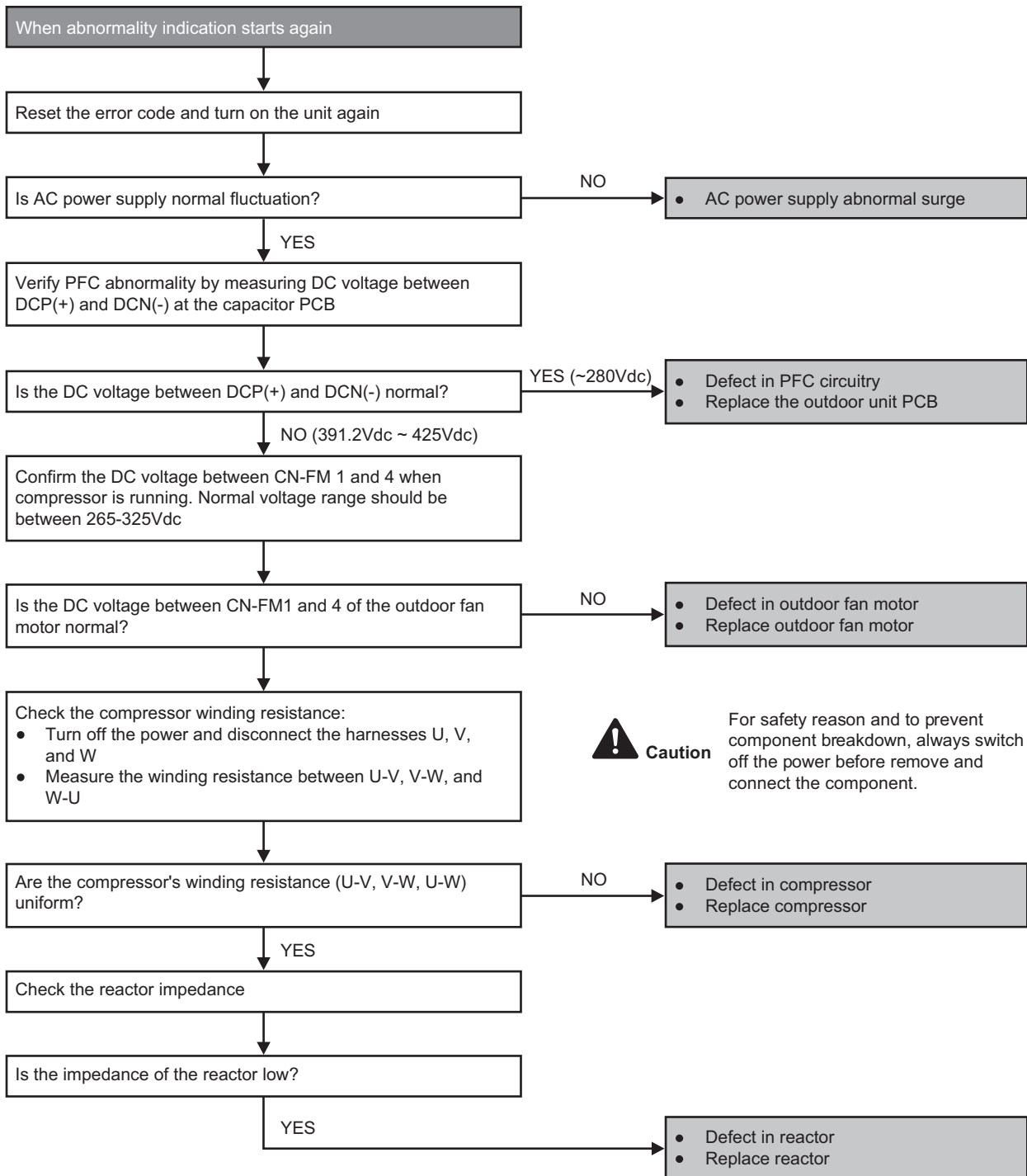

### 15.5.18 F91 (Refrigeration Cycle Abnormality)

#### Malfunction Decision Conditions

- The input current is low while the compressor is running at higher than the setting frequency.

#### Malfunction Caused

- Lack of gas.
- 3-way valve close.

#### Troubleshooting

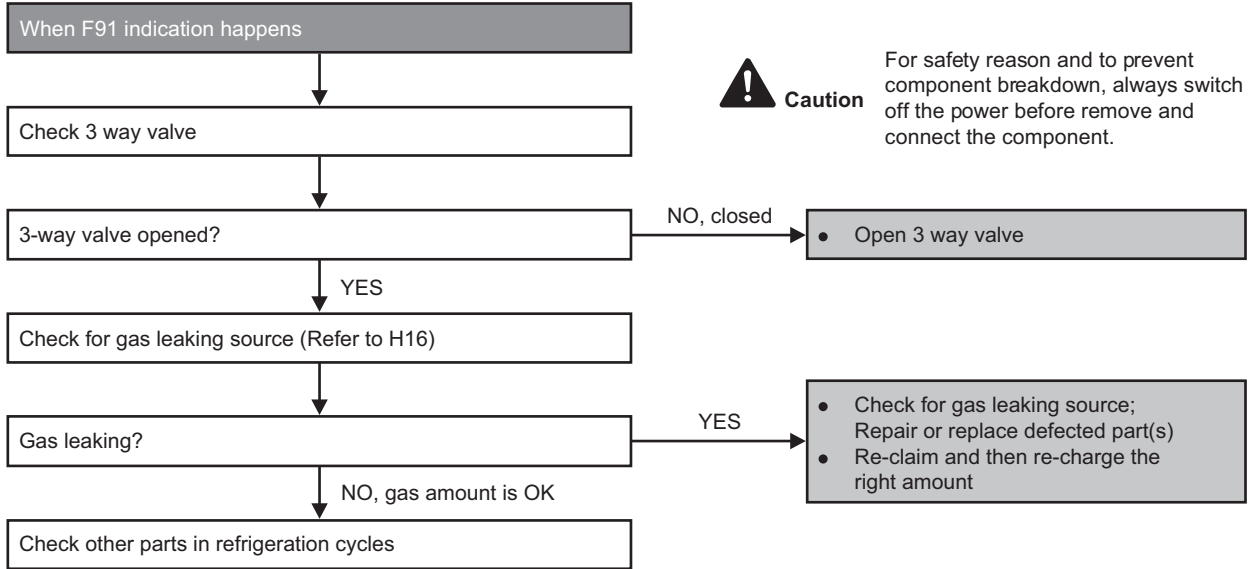

## 15.5.19 F93 (Compressor Rotation Failure)

### Malfunction Decision Conditions

- A compressor rotation failure is detected by checking the compressor running condition through the position detection circuit.

### Malfunction Caused

- Compressor terminal disconnect
- Faulty Outdoor PCB
- Faulty compressor

### Troubleshooting

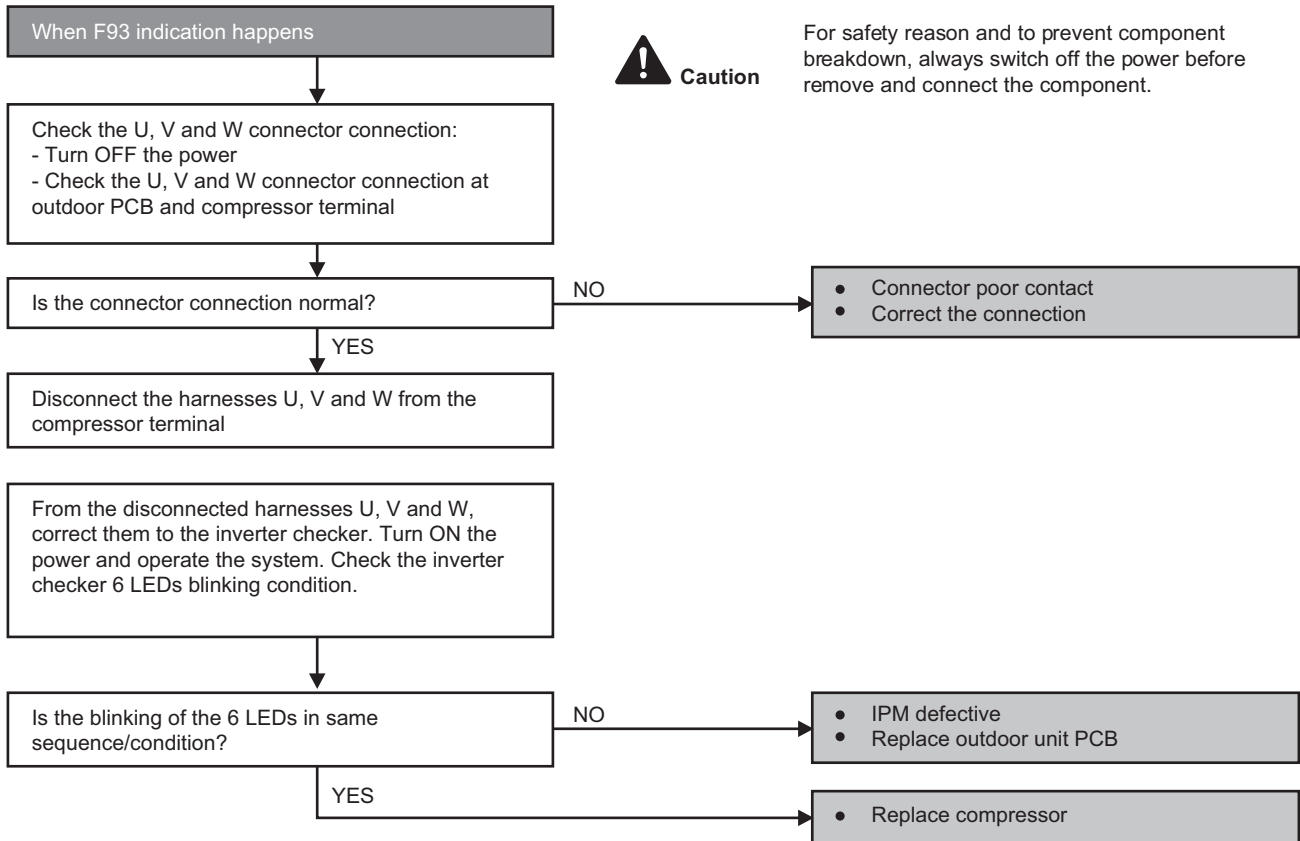

## 15.5.20 F95 (Outdoor High Pressure Protection: Cooling or Soft Dry)

### Malfunction Decision Conditions

- During operation of cooling or soft dry, when outdoor unit heat exchanger high temperature data is detected by the outdoor unit heat exchanger thermistor.

### Malfunction Caused

- Outdoor heat exchanger temperature rise due to short-circuit of hot discharge air flow.
- Outdoor heat exchanger temperature rise due to defective of outdoor fan motor.
- Outdoor heat exchange temperature rise due to defective outdoor heat exchanger thermistor.
- Outdoor heat exchanger temperature rise due to defective of outdoor unit PCB.

### Troubleshooting

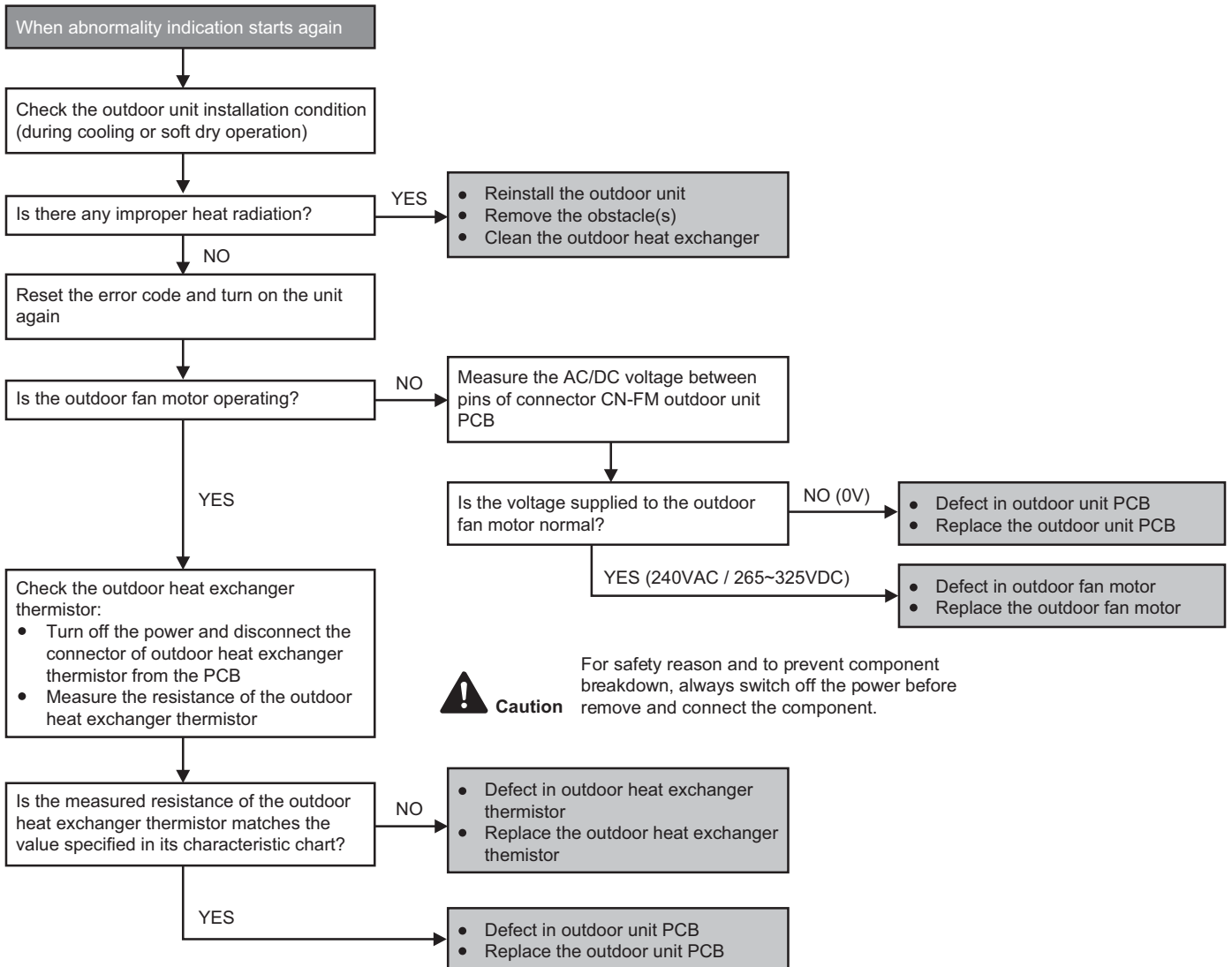

## 15.5.21 F96 (IPM Overheating)

### Malfunction Decision Conditions

- During operating of cooling and heating, when IPM temperature data (100°C) is detected by the IPM temperature sensor.

#### *Multi Models only*

- Compressor Overheating: During operation of cooling and heating, when the compressor OL is activated.
- Heat Sink Overheating: During operation of cooling and heating, when heat sink temperature data (90°C) is detected by the heat sink temperature sensor.

### Malfunction Caused

- IPM overheats due to short circuit of hot discharge air flow.
- IPM overheats due to defective of outdoor fan motor.
- IPM overheats due to defective of internal circuitry of IPM.
- IPM overheats due to defective IPM temperature sensor.

#### *Multi Models Only*

- Compressor OL connector poor contact.
- Compressor OL faulty.

### Troubleshooting

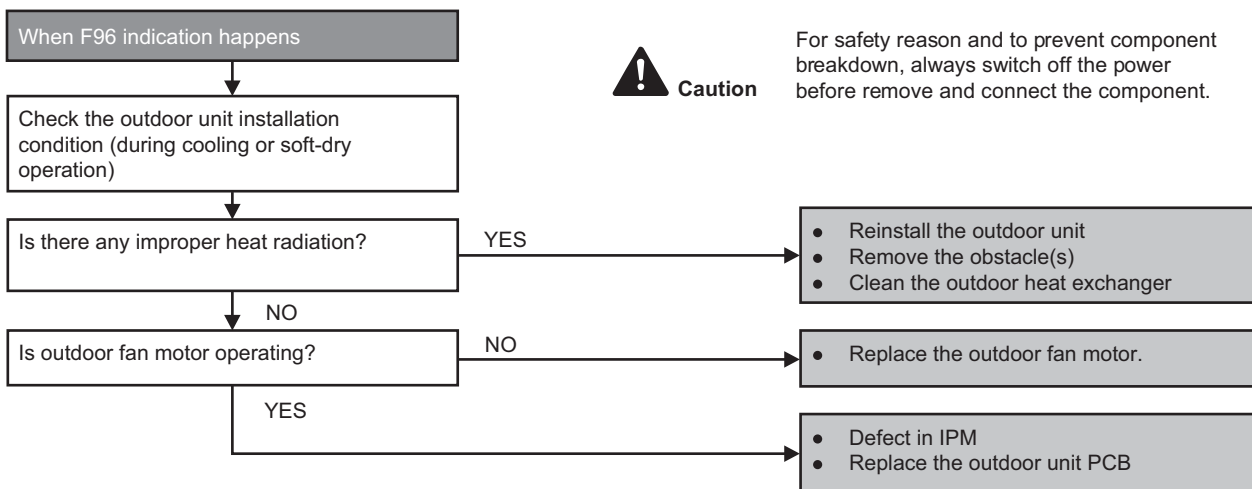

## 15.5.22 F97 (Compressor Overheating)

### Malfunction Decision Conditions

- During operation of cooling and heating, when compressor tank temperature data (112°C) is detected by the compressor tank temperature sensor.

### Malfunction Caused

- Faulty compressor tank temperature sensor
- 2/3 way valve closed
- Refrigerant shortage (refrigerant leakage)
- Faulty outdoor unit PCB
- Faulty compressor

### Troubleshooting

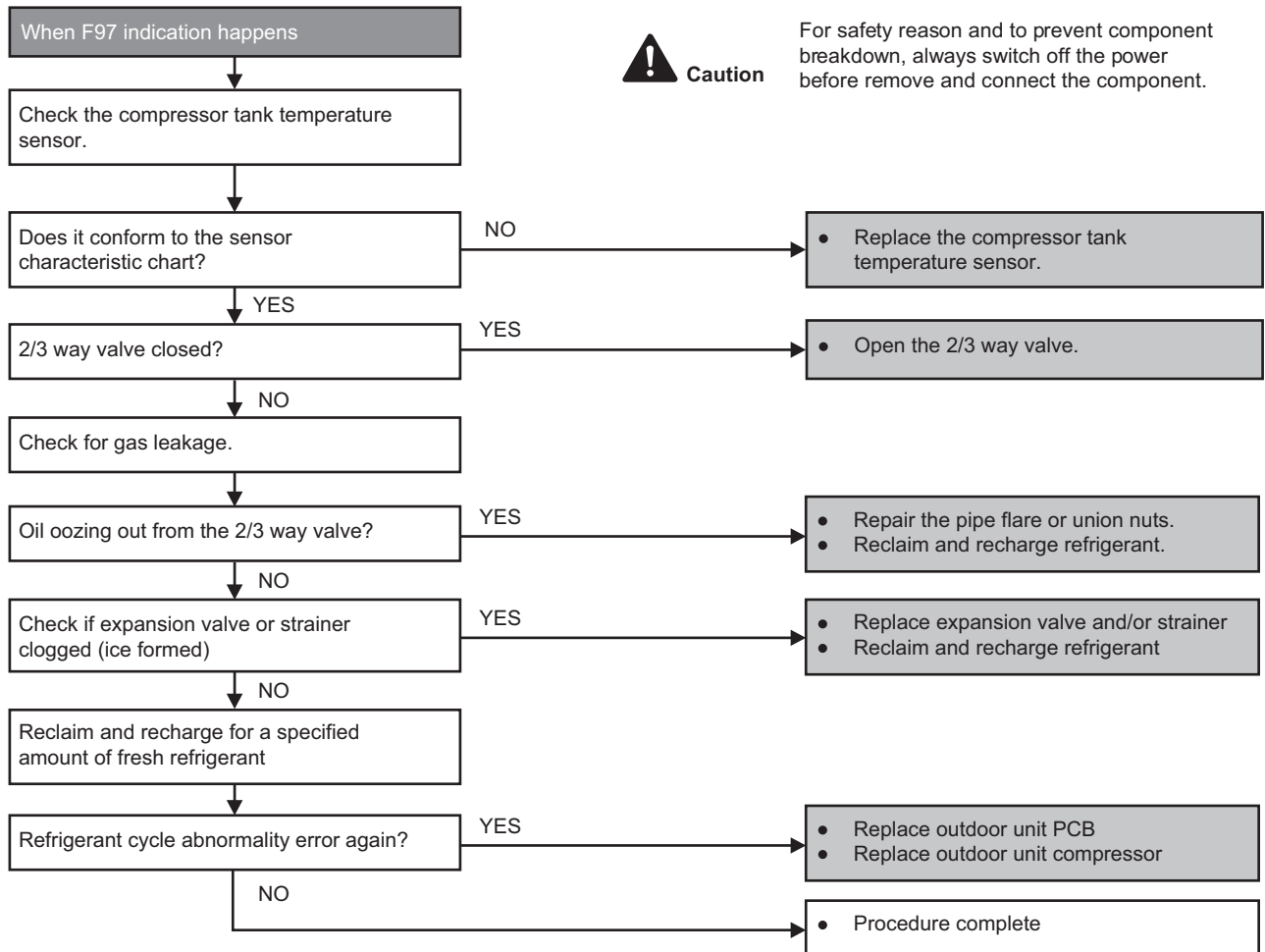

### 15.5.23 F98 (Input Over Current Detection)

#### Malfunction Decision Conditions

- During operation of cooling and heating, when an input over-current (X value in Total Running Current Control) is detected by checking the input current value being detected by current transformer (CT) with the compressor running.

#### Malfunction Caused

- Excessive refrigerant.
- Faulty outdoor unit PCB.

#### Troubleshooting

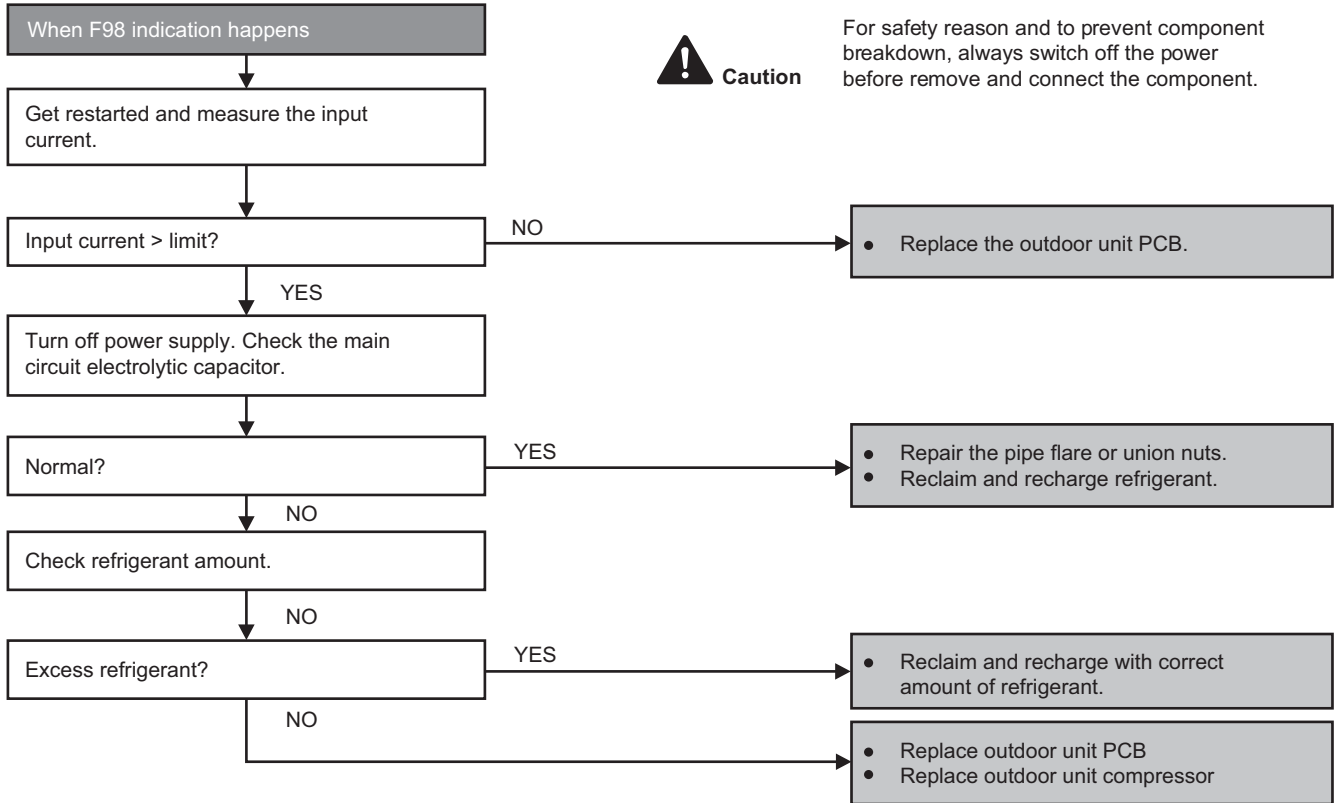



## 15.5.24 F99 (DC Peak Detection)

### Malfunction Decision Conditions

During startup and operation of cooling and heating, when inverter DC peak data is received by the outdoor internal DC Peak sensing circuitry.

### Malfunction Caused

- DC current peak due to compressor failure.
- DC current peak due to defective power transistor(s).
- DC current peak due to defective outdoor unit PCB.
- DC current peak due to short circuit.

### Troubleshooting

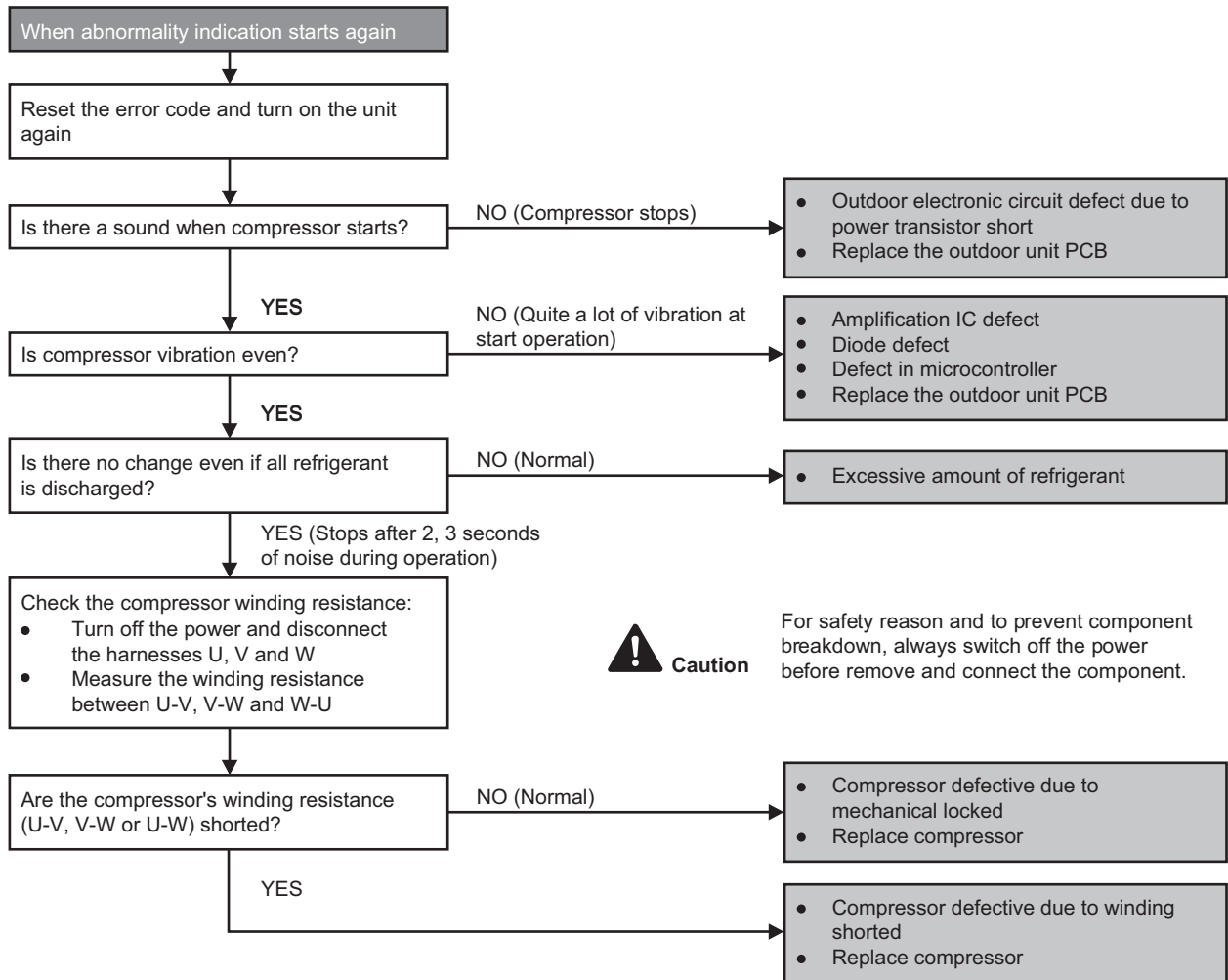

# 16. Disassembly and Assembly Instructions



**WARNING**

High Voltage are generated in the electrical parts area by the capacitor. Ensure that the capacitor has discharged sufficiently before proceeding with repair work. Failure to heed this caution may result in electric shocks.

## 16.1 Indoor Electronic Controller, Blower Fan, Fan Motor & Drain Motor Removal Procedure.

### 16.1.1 To Remove Cabinet Bottom Plate

- 1 Unscrew 14 screws on the cabinet bottom plate, 10 screws on the cabinet top plate and detach cabinet bottom plate and cabinet top plate from unit.

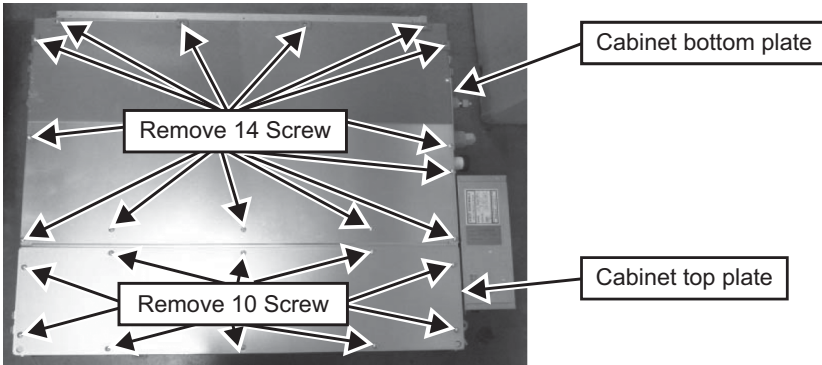

### 16.1.2 To Remove Electronic Controller

- 1 Unscrew the 2 screws on the Control Board and open the Control Board Cover.

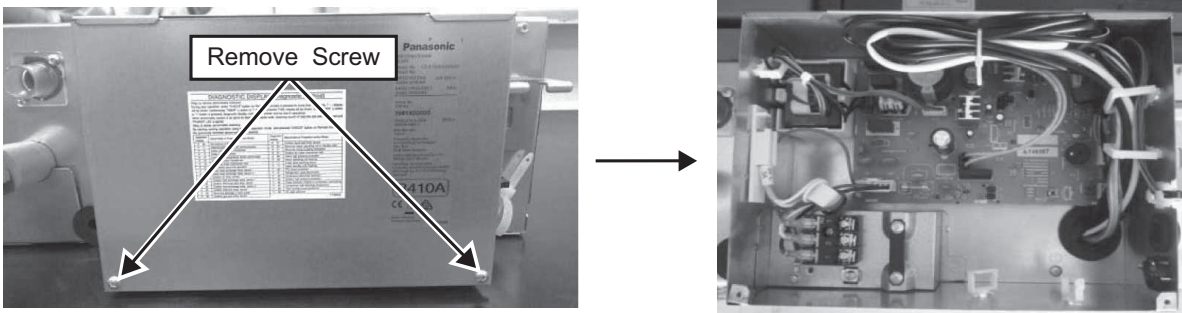

- 2 Detach all connectors as labeled from the electronic controller. Then pull out main controller gently.

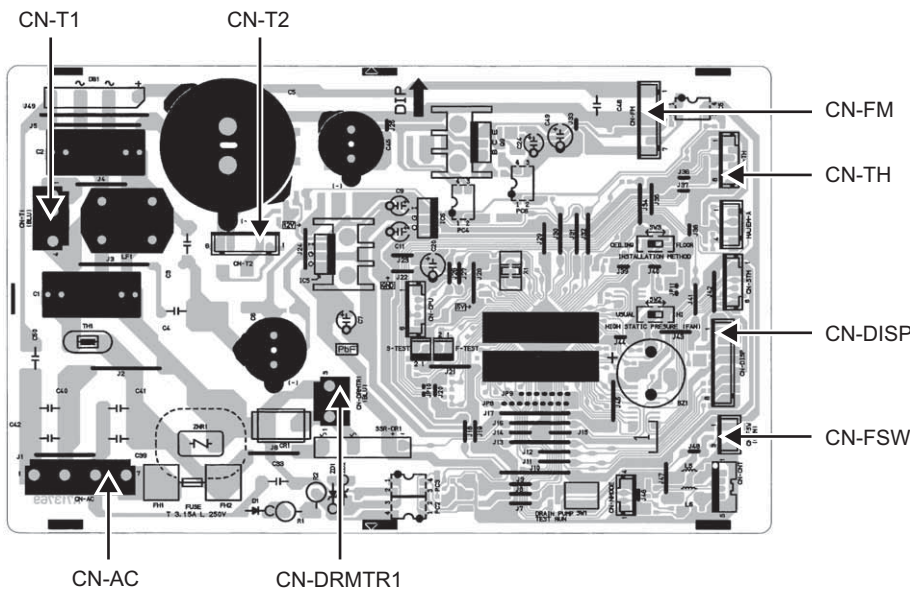

### 16.1.3 To Remove Fan Motor and Blower Fan

- 1 Detach the Upper and Inner Casing
- 2 Disengage the 4 catches (2 each on the left and right) on the Air Guide.

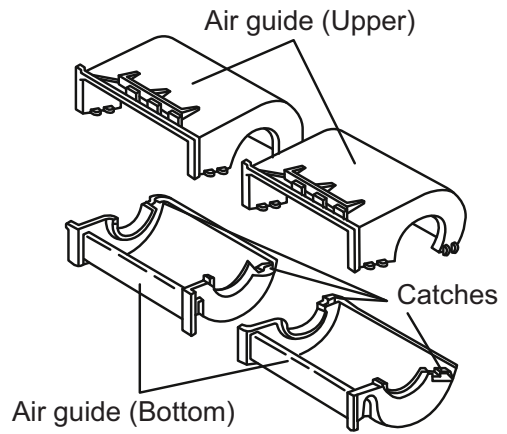
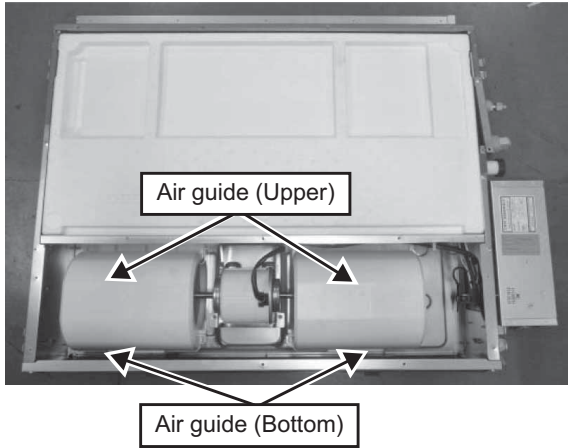

- 3 Unscrew the 2 screws on the Fan Motor Bracket and detach Fan Motor Bracket.
- 4 Remove the Fan Motor and Blower Fan from the unit.
- 5 Use a 3.0 mm hexagonal wrench to loosen the bolts connecting the Fan Motor and Fan. Detach the shaft connecting the Fan Motor and Blower Fan.

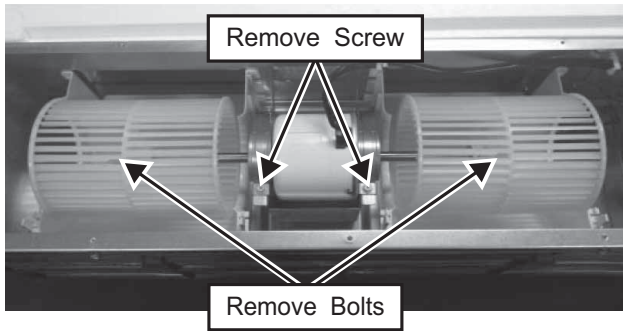

### 16.1.4 To Remove the Drain Motor

- 1 Unscrew the 1 screw on the Side Plate and remove Drain Pan from the unit.

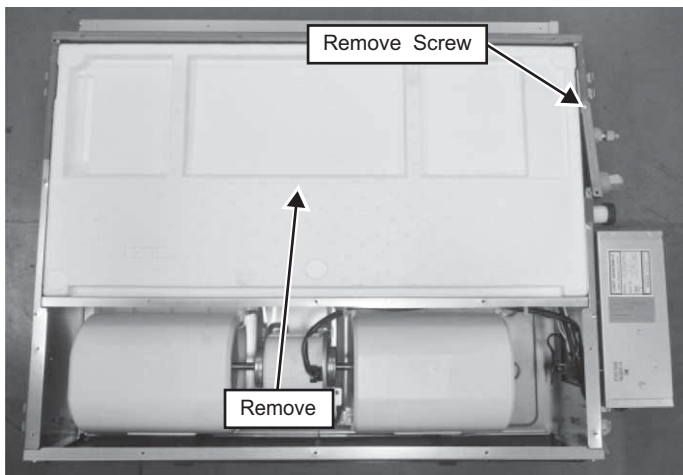

2 Unscrew 5 screws on the Evaporator and remove 2 sensor from holder and remove Evaporator from the unit.

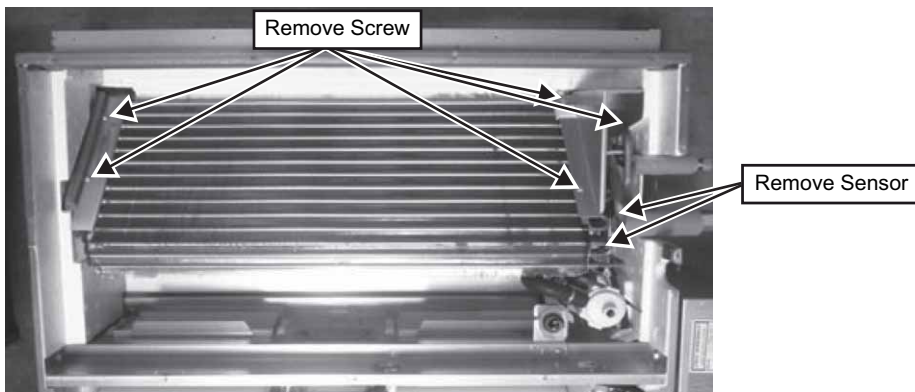

3 Unscrew 4 screws, 1 nut and 1 Spring Clip on the Drain Motor Bracket and remove Drain Motor from unit.

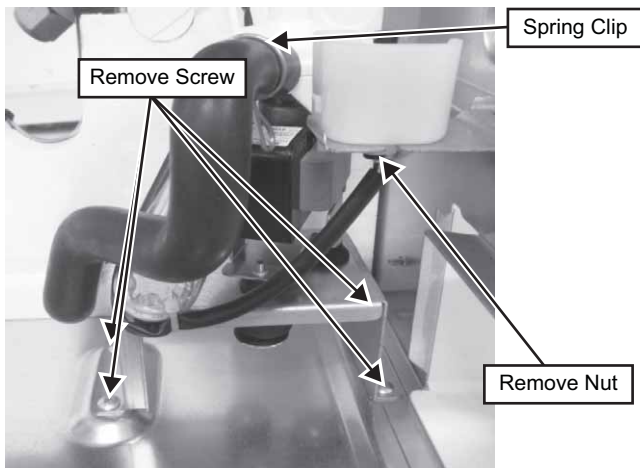

4 Unscrew 3 screws on the Drain Motor and detach the Drain Motor from Drain Motor Bracket.

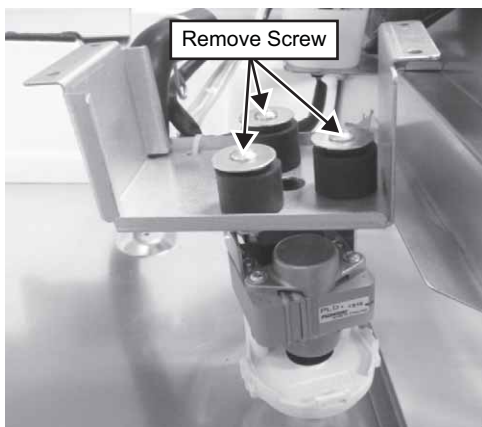

## 16.2 Outdoor Electronic Controller Removal Procedure

- 1 Remove the 4 screws of the Top Panel.

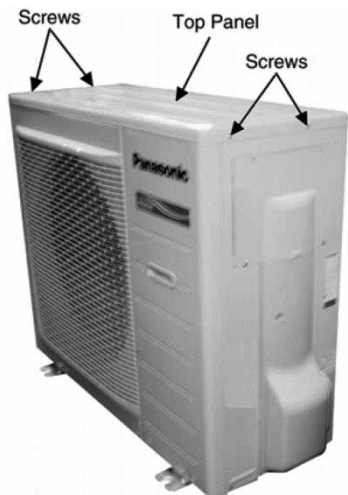

Fig. 1

- 2 Remove the 10 screws of the Front Panel.

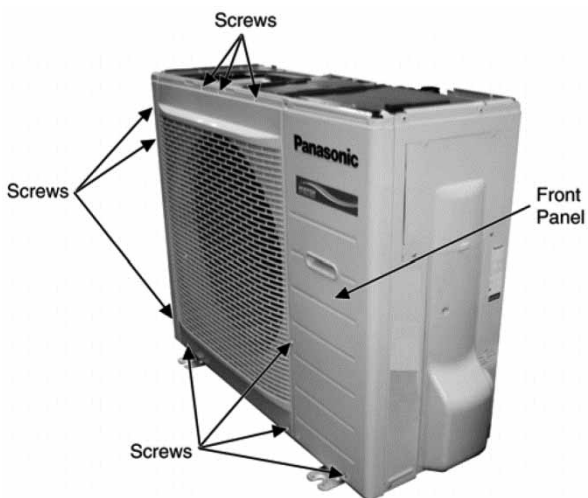

Fig. 2

- 3 Remove the Top Cover of the Electronic Controller.



Fig. 3

- 4 Remove the Control Board.

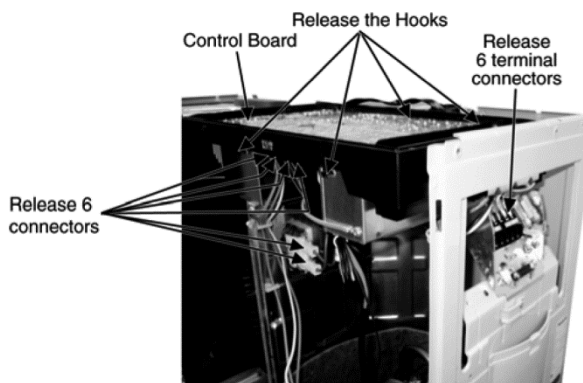

Fig. 4

- 5 Remove the 8 screws of the Electronic Controller.

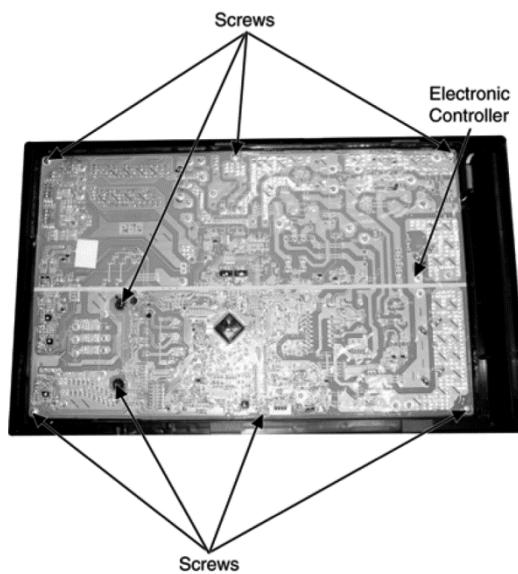



Fig. 5

 Caution! When handling electronic controller, be careful of electrostatic discharge.

## 17. Technical Data

Technical data provided are based on the air conditioner running under free frequency.

### 17.1 Cool Mode Performance Data

Unit setting: Standard piping length, Hi Fan, Cool mode at 16°C

Voltage: 220V/230V

Indoor (°C)		Outdoor DB (°C)											
DB	WB	-10			-7			0			5		
		TC	SHC	IP	TC	SHC	IP	TC	SHC	IP	TC	SHC	IP
27	19.0	6235	4541	1234	6288	4549	1146	6178	4519	1222	6251	4548	1149
	22.0	6761	3600	1246	6987	3649	1055	6969	3641	991	6892	3593	1144
23	15.7	5059	4346	1100	5242	4211	932	5110	4141	852	5766	4453	1125
	18.4	6297	3591	1051	6107	3551	1227	6051	3529	1277	6011	3506	1245
20	13.3	3908	3571	733	3949	3591	737	4131	3689	648	3844	3493	747
	15.8	5267	3319	1050	5688	3510	926	5882	3603	1085	4385	2850	825

Indoor (°C)		Outdoor DB (°C)								
DB	WB	16			25			35		
		TC	SHC	IP	TC	SHC	IP	TC	SHC	IP
27	19.0	6132	4422	1149	2947	2917	422	5100	4043	1600
	22.0	6790	3563	1138	5125	2964	896	5300	3022	1714
23	15.7	5435	4275	1011	2945	2826	494	4280	3747	1584
	18.4	7082	3999	1417	4594	2372	856	4847	3126	1595
20	13.3	4242	3728	763	2944	2885	566	3582	3384	1592
	15.8	4944	3182	835	4062	2760	816	4412	3031	1589

(Dry bulb value based on 46% humidity)

TC - Total Cooling Capacity (W)

SHC - Sensible Heat Capacity (W)

IP - Input Power (W)

### 17.2 Heat Mode Performance Data

Unit setting: Standard piping length, Hi Fan, Heat mode at 30°C

Voltage: 220V/230V

Indoor (°C)		Outdoor WB (°C)									
DB		-10		-7		2		7		12	
		TC	IP	TC	IP	TC	IP	TC	IP	TC	IP
24		3753	1900	4252	1900	4919	1960	5691	1824	6162	1822
20		4000	1887	4300	1880	5140	1930	6100	1830	6714	1833
16		4267	1869	3869	1662	5169	1888	6563	1834	7170	1829

TC - Total Heating Capacity (W)

IP - Input Power (W)

# 17.3 Fan Performance

## Test Report

Tap	Static Pressure (Pa)	Airflow (m <sup>3</sup> /min)
Lo	-0.1	11.55
	2.7	11.24
	17.8	9.41
	29.0	7.67
	37.7	6.17
	46.1	4.85
Hi	0.1	17.15
	24.4	15.27
	44.6	13.57
	60.4	11.94
	74.5	10.45
	84.1	9.13
	90.3	8.02
	93.4	6.83

Tap	Static Pressure (Pa)	Airflow (m <sup>3</sup> /min)
Me	-0.1	14.57
	11.4	13.45
	30.3	11.67
	43.8	9.93
	54.5	8.38
	63.1	7.12
	68.1	5.79
	-0.1	19.69
Switch Hi	70.7	14.12
	86.6	12.56
	98.5	11.10
	108.2	9.81
	114.9	8.81
	122.0	7.84

### Fan Performance Curve

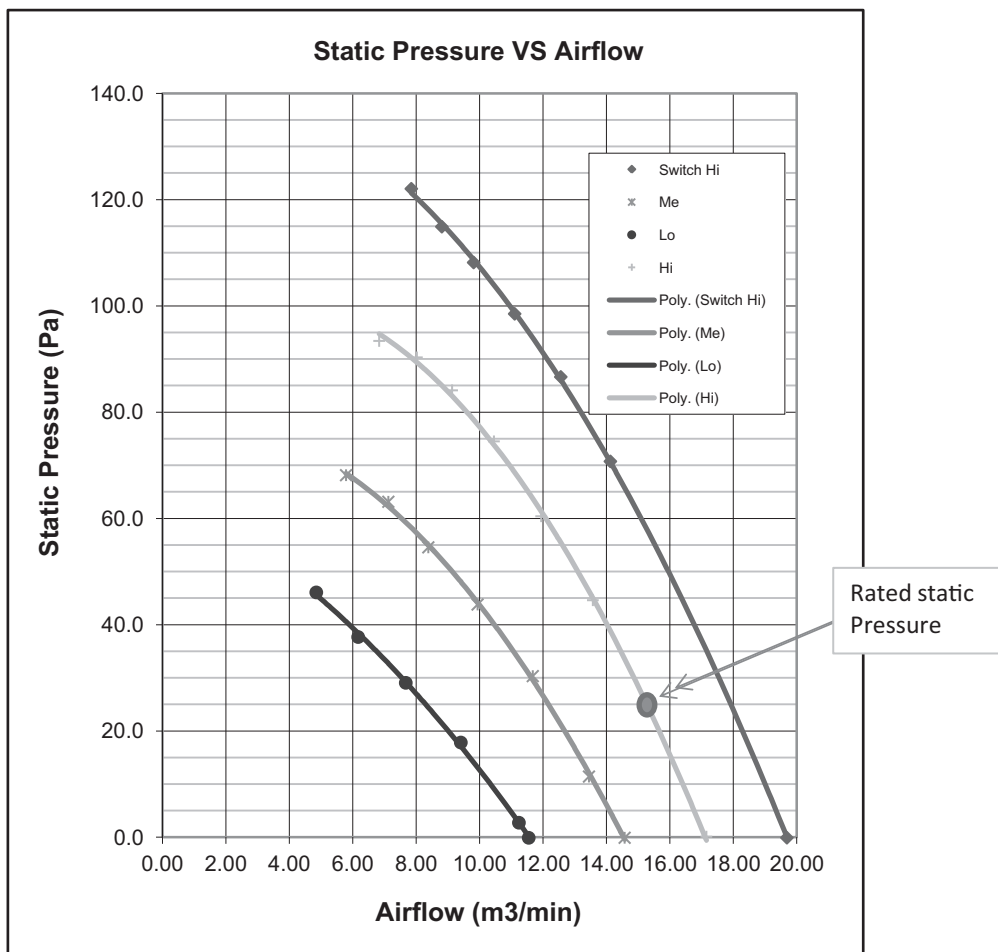

	RPM	Static Pressure	Airflow
Hi Fan (Rated)	1480	25 Pa	15.3
SHi Fan (Hi Static P selected)	1650	57 Pa	15.3
Me Fan (Rated)	1230	21 Pa	12.56
Lo Fan (Rated)	980	17 Pa	9.42

## 18. Service Data

Service data provided are based on the air conditioner running under rated frequency during forced cooling / forced heating mode.

### 18.1 Cool Mode Outdoor Air Temperature Characteristic

Condition

- Indoor room temperature: 27°C DryBulb/19°C Wet Bulb
- Unit setting: Standard piping length, forced cooling at 16°C, Hi fan
- Compressor frequency: Rated for cooling operation
- Voltage: 220V/230V

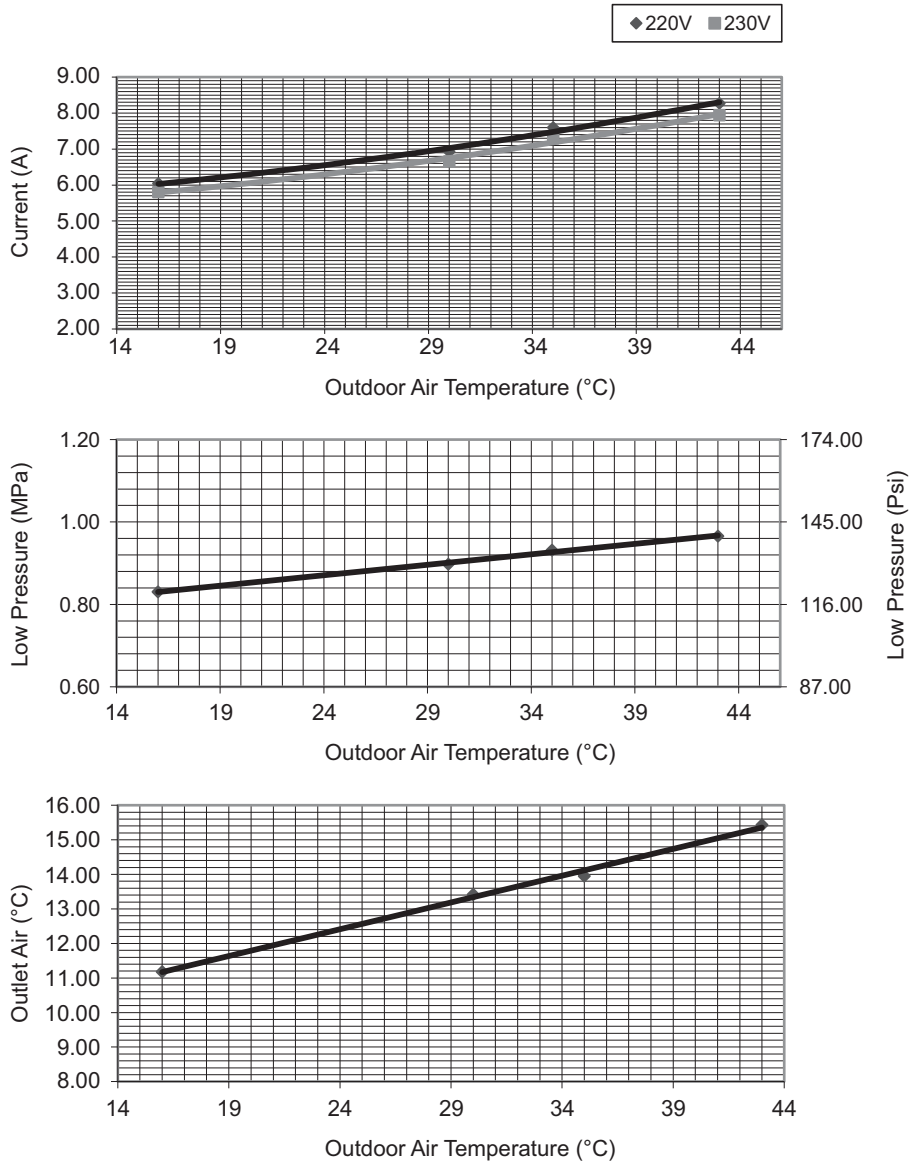



## 18.2 Heat Mode Outdoor Air Temperature Characteristic

Condition

- Indoor room temperature: 20°C DryBulb/ -°C Wet Bulb
- Unit setting: Standard piping length, forced heating at 30°C, Hi fan
- Compressor frequency: Rated for Heating operation
- Voltage: 220V/230V

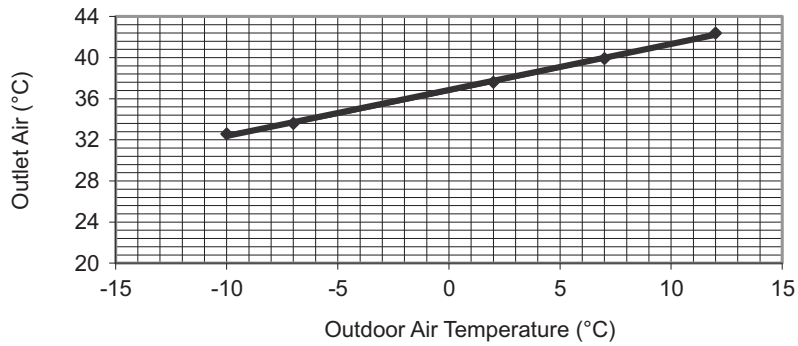
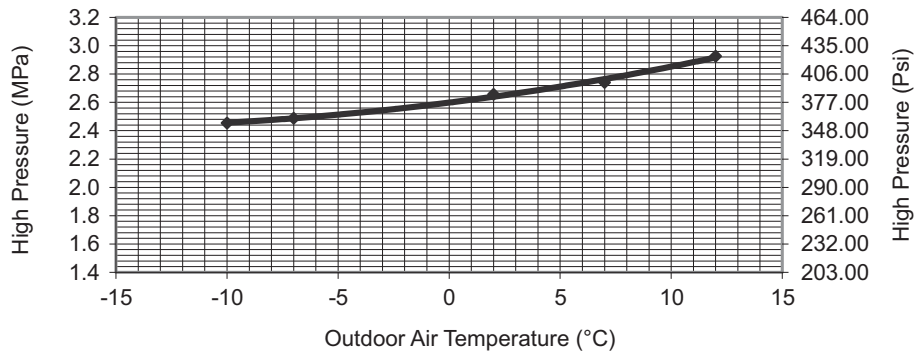
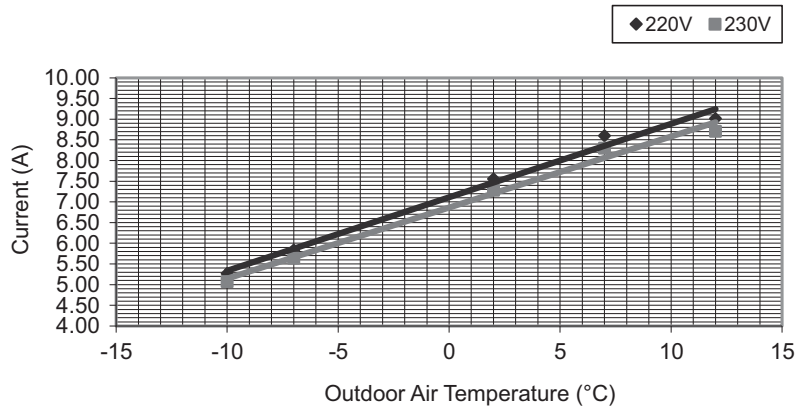

## 18.3 Piping Length Correction Factor

The characteristic of the unit has to be corrected in accordance with the piping length.

### 18.3.1 Cooling Capacity

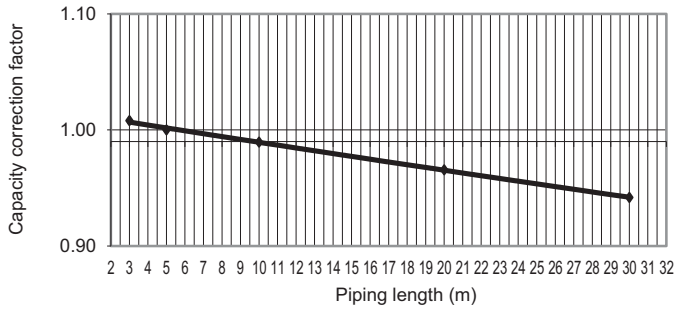

3	1.0080
5	1.0000
10	0.9895
20	0.9656
30	0.9418

### 18.3.2 Heating Capacity

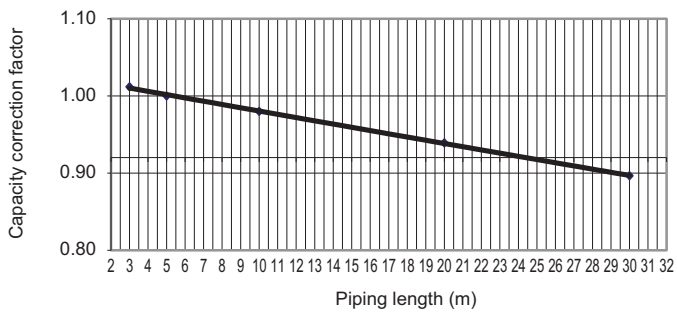

3	1.0118
5	1.0000
10	0.9800
20	0.9392
30	0.8966

Note: The graphs show the factor after added right amount of additional refrigerant.

# 19. Exploded View and Replacement Parts List

## 19.1 Indoor Unit

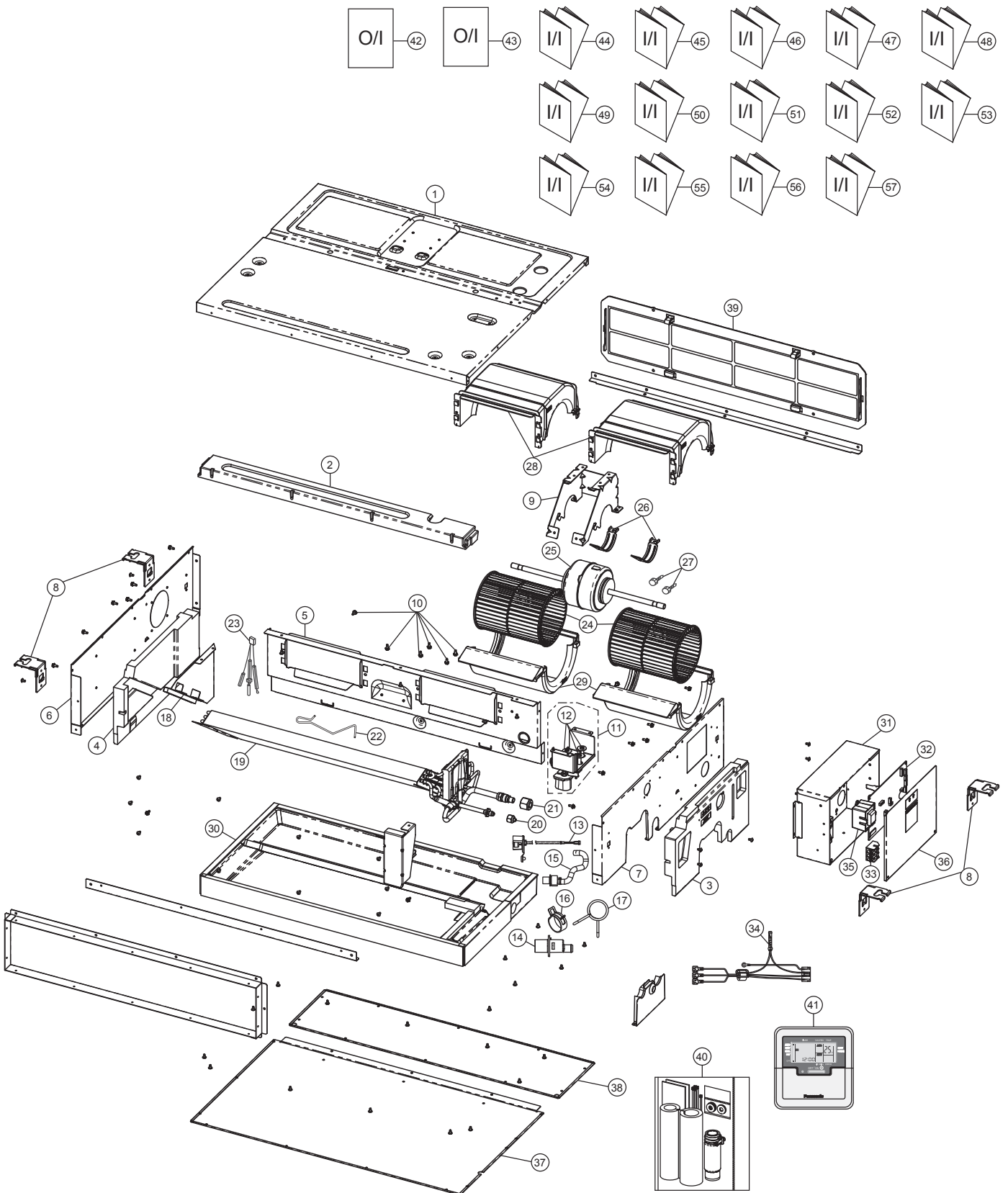

Note:  
The above exploded view is for the purpose of parts disassembly and replacement.  
The non-numbered parts are not kept as standard service parts.

SAFETY	REF NO.	PART NAME & DESCRIPTION	QTY.	CS-E18RD3EAW	REMARK
	1	CABINET TOP PLATE - COMPLETE	1	CWE03C1169	
	2	FOAMED STYRENE COMPLETE	1	CWG07C1094	
	3	FOAMED STYRENE COMPLETE	1	CWG07C1089	
	4	FOAMED STYRENE COMPLETE	1	CWG07C1090	
	5	BULKHEAD	1	CWD531059	
	6	CABINET SIDE PLATE - COMPLETE	1	CWE04C1565	
	7	CABINET SIDE PLATE - COMPLETE	1	CWE04C1566	
	8	PARTICULAR PLATE	4	CWD912571	
	9	FAN MOTOR BRACKET	1	CWD541246	
	10	SCREW - FAN MOTOR BRACKET	6	CWH55406J	
	11	PUMP - COMPLETE	1	CWB53C1056	O
	12	ANTI - VIBRATION BUSHING	3	CWH501131	
	13	FLOAT SWITCH COMPLETE	1	CWA12C1034	O
	14	DRAIN NOZZLE	1	CWH411027	
	15	FLEXIBLE PIPE - COMPLETE	1	CWH85C1120	
	16	PLATE SPRING	1	CWH711022	
	17	WIRE SPRING	1	CWH722018	
	18	PARTICULAR PIECE - COMPLETE	1	CWD93C1191	
	19	FIN & TUBE EVAPORATER - COMPLETE	1	CWB30C5053	O
	20	FLARE NUT (1/4)	1	CWT251030	
	21	FLARE NUT (1/2)	1	CWT251032	
	22	HOLDER - SENSOR	2	CWH32143	
	23	SENSOR COMPLETE	1	CWA50C2556	O
	24	BLOWER WHEEL ASS'Y	2	CWH01K1041	
⚠	25	FAN MOTOR	1	EHDS85AAC	O
	26	FAN MOTOR BRACKET	2	CWD541247	
	27	SCREW - FAN MOTOR BRACKET	2	CWH551049J	
	28	AIR GUIDER B.W.	2	CWD321112	
	29	AIR GUIDER B.W.	2	CWD321113	
	30	DRAIN PAN - COMPLETE	1	CWH40C1134	
	31	CONTROL BOARD A'SSY	1	CWH10K1262	
⚠	32	ELECTRONIC CONTROLLER - (MAIN)	1	CWA73C9302	O
⚠	33	TERMINAL BOARD ASS'Y	1	CWA28K1045J	
	34	FUSE - COMPLETE	1	CWA16C1038	
⚠	35	TRANSFORMER - COMPLETE	1	CWA40C1027	O
	36	CONTROL BOARD COVER	1	CWH13C1358	
	37	CABINET BOTTOM PLATE - COMPLETE	1	CWE05C1014	
	38	CABINET TOP PLATE	1	CWE031215	
	39	AIR FILTER	1	CWD001390	
	40	ACCESSORY - COMPLETE	1	CWH82C2111	
	41	WIRED REMOTE CONTROL COMPLETE	1	CWA75C4264	O
	42	OPERATING INSTRUCTION	1	CWF569921	
	43	OPERATING INSTRUCTION	1	CWF569930	
	44	INSTALLATION INSTRUCTION	1	CWF616767	
	45	INSTALLATION INSTRUCTION	1	CWF616768	
	46	INSTALLATION INSTRUCTION	1	CWF616769	
	47	INSTALLATION INSTRUCTION	1	CWF616770	
	48	INSTALLATION INSTRUCTION	1	CWF616771	
	49	INSTALLATION INSTRUCTION	1	CWF616772	
	50	INSTALLATION INSTRUCTION	1	CWF616773	

SAFETY	REF NO.	PART NAME & DESCRIPTION	QTY.	CS-E18RD3EAW	REMARK
	51	INSTALLATION INSTRUCTION	1	CWF616774	
	52	INSTALLATION INSTRUCTION	1	CWF616775	
	53	INSTALLATION INSTRUCTION	1	CWF616776	
	54	INSTALLATION INSTRUCTION	1	CWF616777	
	55	INSTALLATION INSTRUCTION	1	CWF616778	
	56	INSTALLATION INSTRUCTION	1	CWF616779	
	57	INSTALLATION INSTRUCTION	1	CWF616780	

(Note)

- All parts are supplied from PAPAMY, Malaysia (Vendor Code: 00029488).
- “O” marked parts are recommended to be kept in stock.

## 19.2 Outdoor Unit

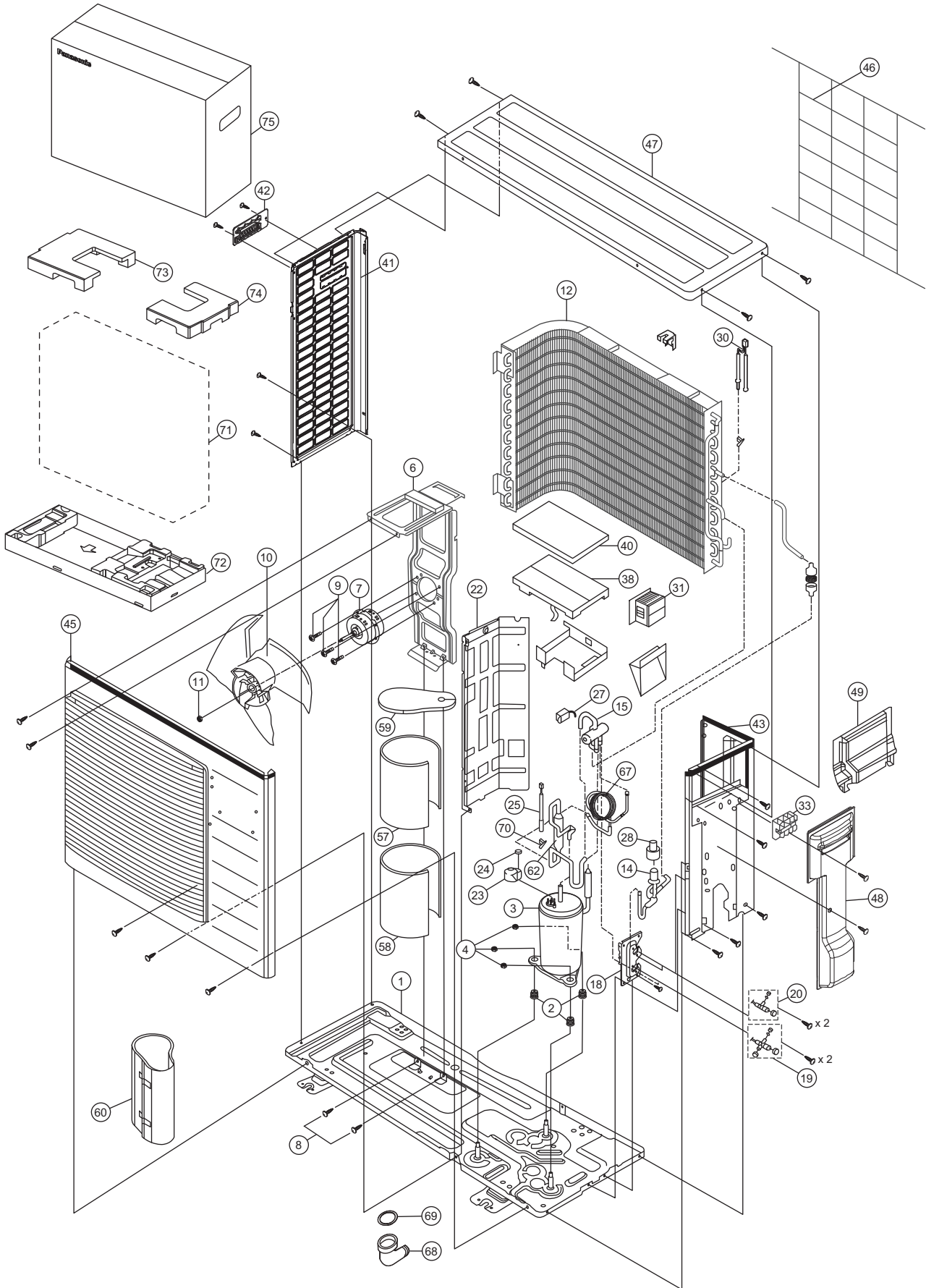

Note:  
The above exploded view is for the purpose of parts disassembly and replacement.  
The non-numbered parts are not kept as standard service parts.

SAFETY	REF NO.	DESCRIPTION & NAME	QTY.	CU-E18RBEA	REMARK
	1	CHASSIS COMPLETE	1	CWD52K1261	
	2	ANTI - VIBRATION BUSHING	3	CWH50077	
	3	COMPRESSOR	1	5RD132XBA21	O
	4	NUT - COMPRESSOR MOUNT	3	CWH561096	
	6	FAN MOTOR BRACKET	1	CWD541153	
	7	FAN MOTOR	1	ARW8401AC	O
	8	SCREW - FAN MOTOR BRACKET	2	CWH551217	
	9	SCREW - FAN MOTOR MOUNT	4	CWH551106J	
	10	PROPELLER FAN ASSY	1	CWH03K1065	
	11	NUT - PROPELLER FAN	1	CWH56053J	
	12	CONDENSER	1	CWB32C3371	
	14	EXPANSION VALVE	1	CWB051016J	O
	15	4-WAYS VALVE	1	CWB001026J	O
	18	HOLDER COUPLING	1	CWH351227	
	19	3-WAY VALVE (GAS)	1	CWB011338	O
	20	2-WAYS VALVE (LIQUID)	1	CWB021454	O
	22	SOUND PROOF BOARD	1	CWH151257	
	23	TERMINAL COVER	1	CWH171039A	
	24	NUT - TERMINAL COVER	1	CWH7080300J	
	25	SENSOR COMPLETE (COMP TEMP)	1	CWA50C2185	O
	27	V-COIL COMPLETE (4-WAY VALVE)	1	CWA43C2169J	O
	28	V-COIL COMPLETE (EXP. VALVE)	1	CWA43C2257	O
	30	SENSOR - COMPLETE (AIR TEMP AND PIPE TEMP)	1	CWA50C2517	O
	31	REACTOR	1	G0C203J00003	O
	33	TERMINAL BOARD ASSY	1	CWA28K1110J	O
	38	ELECTRONIC CONTROLLER - MAIN	1	CWA73C9189R	O
	40	CONTROL BOARD COVER - TOP	1	CWH131333	
	41	CABINET SIDE PLATE (LEFT)	1	CWE041520A	
	42	HANDLE	1	CWE161010	
	43	CABINET SIDE PLATE COMPLETE	1	CWE041555A	
	45	CABINET FRONT PLATE CO.	1	CWE06K1077	
	46	WIRE NET	1	CWD041155A	
	47	CABINET TOP PLATE	1	CWE031083A	
	48	CONTROL BOARD COVER - COMPLETE	1	CWH13C1238	
	49	CONTROL BOARD COVER	1	CWH131409A	
	57	SOUND PROOF MATERIAL	1	CWG302600	
	58	SOUND PROOF MATERIAL	1	CWG302638	
	59	SOUND PROOF MATERIAL	1	CWG302630	
	60	SOUND PROOF MATERIAL	1	CWG302950	
	62	OIL SEPARATER ASS'Y	1	CWB16K1024	
	67	CAPILLARY TUBE ASS'Y	1	CWB15K1487	
	68	L - TUBE (DRAIN HOSE)	1	CWH5850080	
	69	PACKING - L. TUBE	1	CWB81012	
	70	HOLDER SENSOR	1	CWH32143	
	71	BAG	1	CWG861461	
	72	BASE BOARD - COMPLETE	1	CWG62C1131	
	73	SHOCK ABSORBER (LEFT)	1	CWG713217	

SAFETY	REF NO.	DESCRIPTION & NAME	QTY.	CU-E18RBEA	REMARK
	74	SHOCK ABSORBER (RIGHT)	1	CWG713218	
	75	C.C. CASE	1	CWG568359	

(NOTE)

- All parts are supplied from PAPAMY, Malaysia (Vendor Code: 00029488).
- “O” marked parts are recommended to be kept in stock.