

INSTALLATION INSTRUCTIONS

– Solenoid Valve Kit – for 3-Way ECO-i System

CZ-PXXXHR3

For safety installation and trouble-free operation, you must:

- Carefully read this instruction booklet before beginning.
- Follow each installation or repair step exactly as shown.
- Observe all local, state, and national electrical codes.
- Pay close attention to all warning and caution notices given in this manual.



WARNING



This symbol refers to a hazard or unsafe practice which can result in severe personal injury or death.



CAUTION

This symbol refers to a hazard or unsafe practice which can result in personal injury or product or property damage.

1. Accessories

Part Name	Figure	Q'ty	Remarks
Washer		2	For hanging bolts
Hanging hook		1	Used to hang the solenoid valve kit
Tapping screw (4×12)		4	For hanging bolts

2. Positioning for Installation

- The solenoid valve kit must be installed at a location within 30 m of the indoor unit. However, the length of wiring provided with the solenoid valve kit is 5 m. If the valve will be used with wiring that exceeds 5 m in length, use a terminal box (field supply) or similar device to extend the wiring. Refer to “4. Wiring, Tubing, and Heat Insulation.”
- The solenoid valve kit produces some refrigerant noise. If it is to be installed in a quiet place such as a hospital, library or hotel, it is recommended that the solenoid valve kit be installed in the ceiling of a corridor, etc. apart from the room.
- The solenoid valve kit must be located not less than 2.5m above the floor or that cannot be touched.

Recommended installation

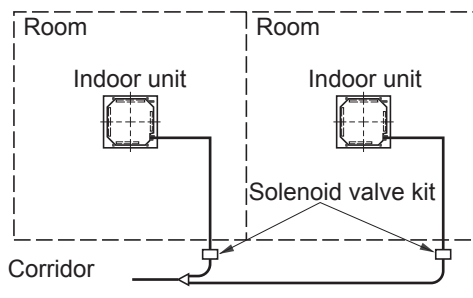

Avoid

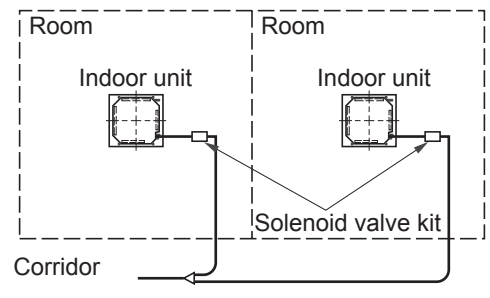

- Be sure to secure the solenoid valve kit with the hanging bolts not to cause any falling damage, using the hanging hooks.
Do not place the solenoid valve kit directly on the ceiling surface. Select a location where the ceiling is enough to support the weight of the solenoid valve Kit.
When installing the solenoid valve kit, **remember to install it with the top surface facing upward.** (See the figure shown in the subsection “How to use the fittings” in “3. Valve Dimensions and Hanging Method.”)

- When installing the valve body, install with the top surface facing up. Secure 200mm or more of space to the front upward so that the service panel can be removed upward.

- **Never conduct drilling or welding on the sheet metal.** Place the solenoid valve kit so that it does not hinder draining.
- Do not cover air holes.

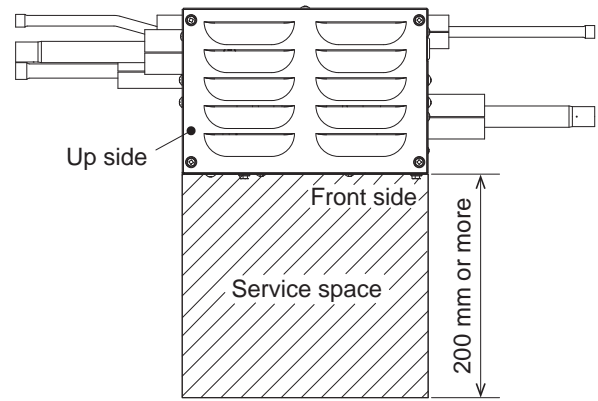
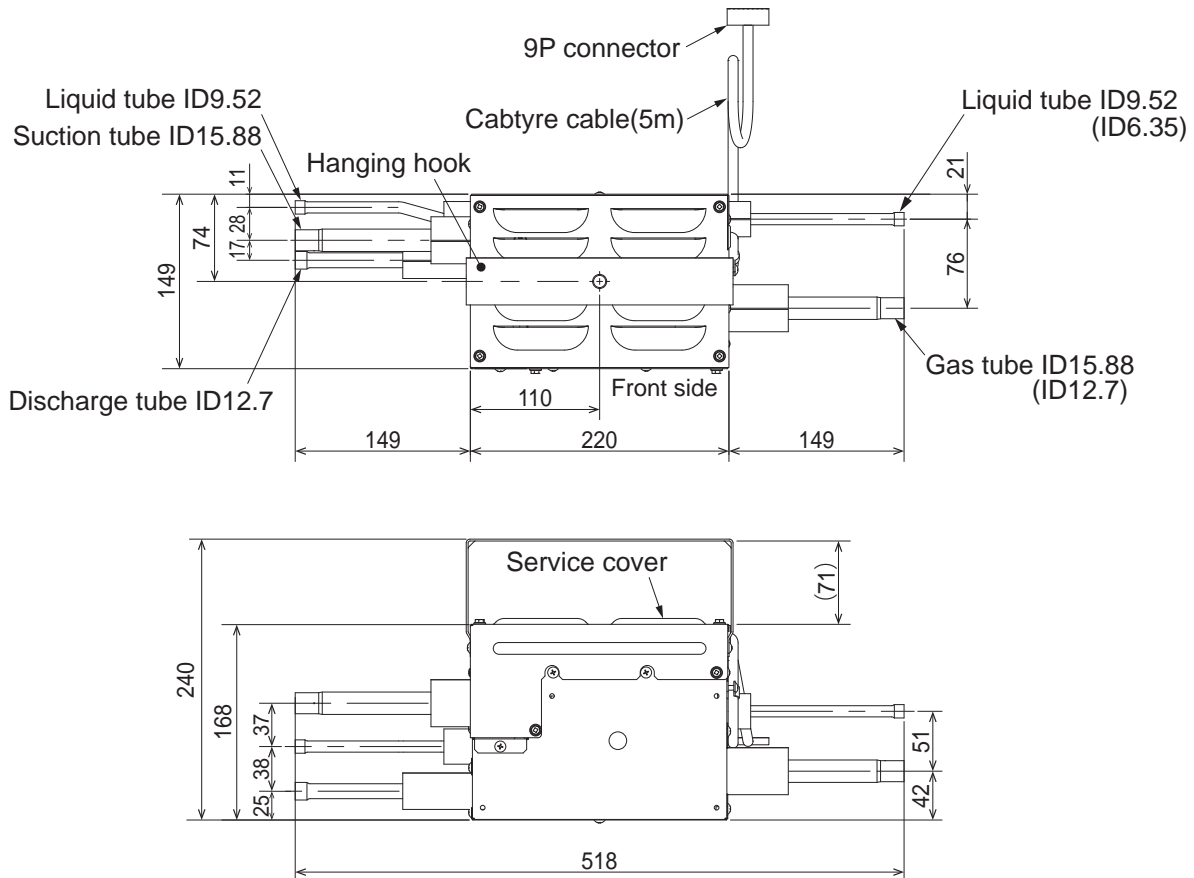

Fig. 1 Service space

3. Valve Dimensions and Hanging Method

- There are 2 types of solenoid valve kits: type 56 and type 160. The corresponding indoor unit model capacities are shown in the table at right.

Solenoid Valve Kit	Indoor Unit Capacity
CZ-P56HR3	22 – 56 Type
CZ-P160HR3	71 – 160 Type
$\left(\begin{array}{l} \text{CZ-P160HR3} \times 2 \\ \text{or} \\ \text{CZ-P56HR3} \times 1 \\ + \\ \text{CZ-P160HR3} \times 1 \end{array} \right)$	224 Type
CZ-P160HR3 × 2	280 Type



Note: This figure shows the unit with suspension fittings attached.

How to use the fittings

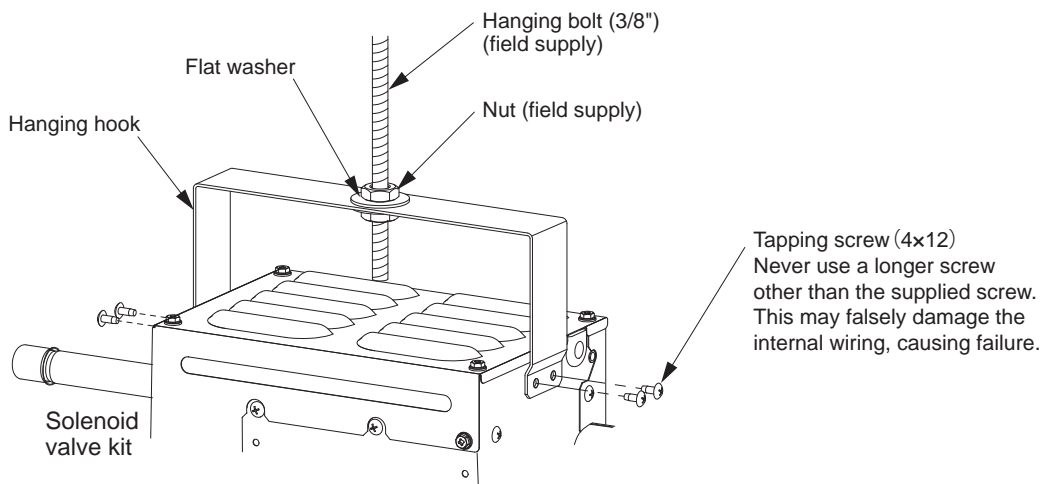

- Be sure to attach the supplied hanging hook.

4. Wiring, Tubing, and Heat Insulation

1. Refrigerant tubing

Cool with damp cloth or other means when brazing the joint with a torch. Otherwise, the solenoid valve will be damaged.

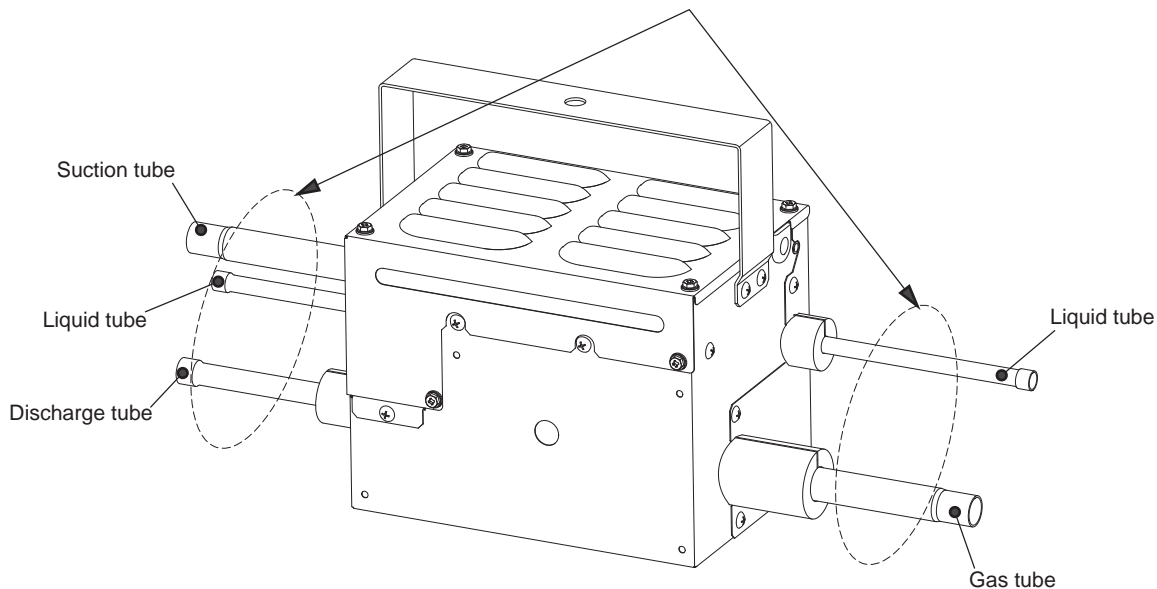

- When brazing, be sure to perform nitrogen replacement inside the tube so that oxidation coating does not form inside the tube.

2. Wiring

Connect the 9P connector coming from the solenoid valve kit through the power inlet of the indoor unit to the 9P connector (red) of the Solenoid Valve Control PCB (sold separately). (Fig. 2)

Accessory wire length is 5 m.

In case the wire is not long enough, cut the wire halfway and connect additional wire (field supply) as an extension using a terminal box (field supply).

Additional wire must be "H05VVF 0.5mm²" or "60227 IEC53".

Anchor the cabtyre cable using the binding bands inside the unit.

Do not route the cabtyre cable through the same wiring conduit as the remote controller wiring or inter-unit control wiring.

If the supply cord is damaged, it must be replaced by the manufacturer, its service agent or similarly qualified persons in order to avoid a hazard.

NOTE

The wire should be fixed with the clamp inside the indoor unit.

Do not route the wire through a tube together with the remote-control line and inter-unit operation line.

- Recommended wire size
6-core cable, 0.5 mm² or more (300V or more)
- Grounding should be done between the indoor unit and solenoid valve kit.

If required wire length is less than 5 m

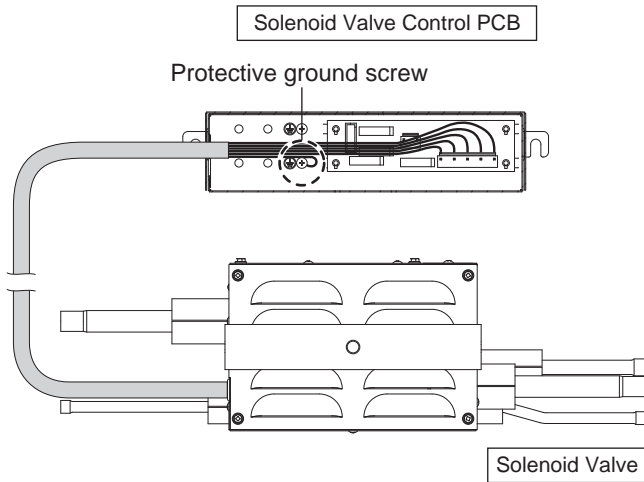
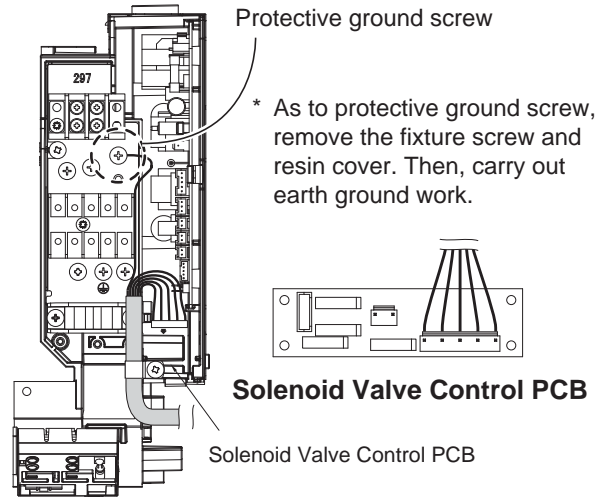

Fig. 2-1 Connection

Indoor unit : K1 type (45 ~ 106)



Front view

Fig. 2-2 Connection for S-45 ~ 106MK1E5

Indoor unit : E1 type (224 ~ 280)

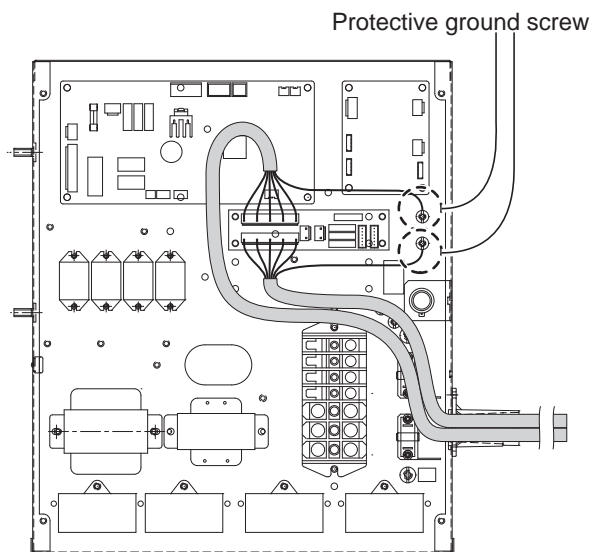
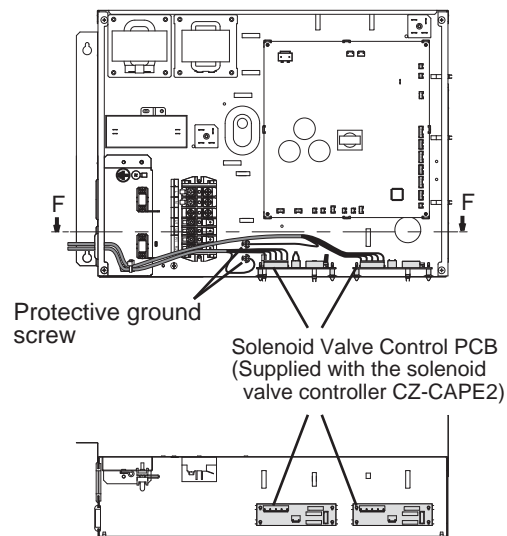

Fig. 2-3 Connection for S-224 ~ 280ME1E5

Indoor unit : E2 type (224 ~ 280)



Cross-section view in the direction of the arrow along the line F - F

Fig. 2-4 Connection for S-224 ~ 280ME2E5

3. Heat Insulation

(Be sure to insulate the tubing after finishing leak inspection.)

- Be sure to insulate the tubing.
- Wrap insulators (field supply) having a thickness of 10 mm or more with heat resistance of 120°C or more around the discharge tubes and gas tubes, and 80°C or more around the suction tubes and liquid tubes.
- Use the supplied thermal insulation tape to bind the areas where there are seams and gaps between the thermal insulation that is wrapped around each tube.
- Failure to conduct thermal insulation may cause water leakage due to condensation.