

# ECO FLOWATCH® DESIGN

Complete kit, in-duct pump, for the condensate removal of air conditioners up to 10kW / 36000BTU.

Ref: DE05LCD320

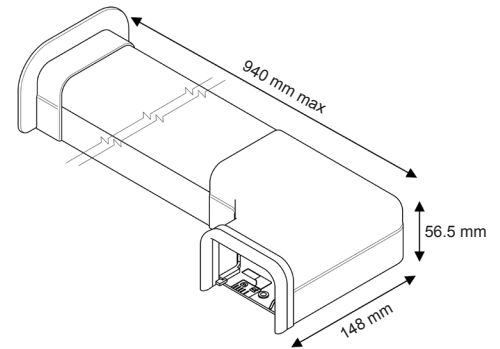
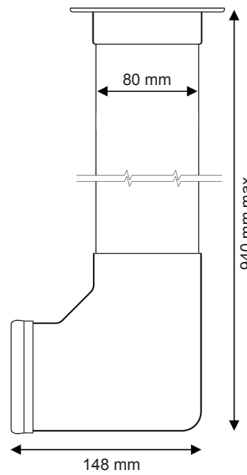
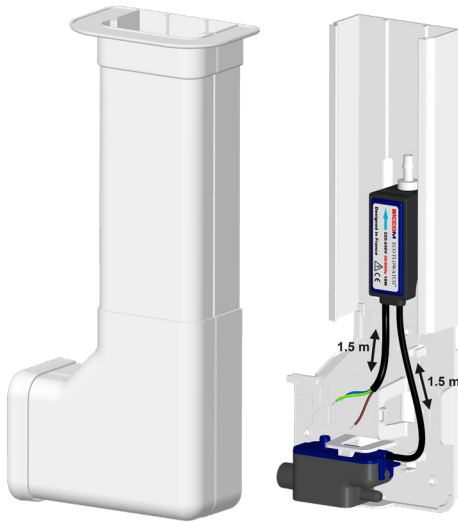

Hose diameter  
Suction : 6/9 mm - not supplied  
Discharge : 6/9 mm - not supplied



## SPECIFICATIONS

Flowrate max	13.2 l/h
Suction head max	1.5 m
Discharge head	10 m
Electrical power	19W
Voltage	220-240V 50/60Hz
Alarm	No alarm
Noise level*	
Protection rating	IP20
Thermal protection	Yes
Operating cycle**	100%
Power cable	1.5 m
Trunking dimensions	80 x 55 x 800 m

\* Notation from 1 wave ( $\leq 20$  dBA) to 6 waves ( $> 45$  dBA)

\*\* The pump is able to run 100% of the time if necessary.

## BENEFITS

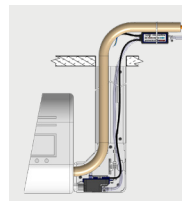

### Possibility to move the pump away

Thanks to its 1.5 m cable, the pump unit can be moved away to reduce the noise level and facilitate installation.



### Removable reservoir

Can be easily unclipped in order to clean the reservoir and the float.



### Integrated filter

Plastic filter integrated to the reservoir. It prevents big impurities to damage the pump.



### Accessories included

All necessary accessories are included in the box.

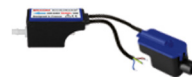

### Compact pump

Very small, pump and reservoir are easy to install.



### Nice design

Thanks to its shape and its finishing accessories (included), the ECO FLOWATCH® DESIGN offers great aesthetics qualities.

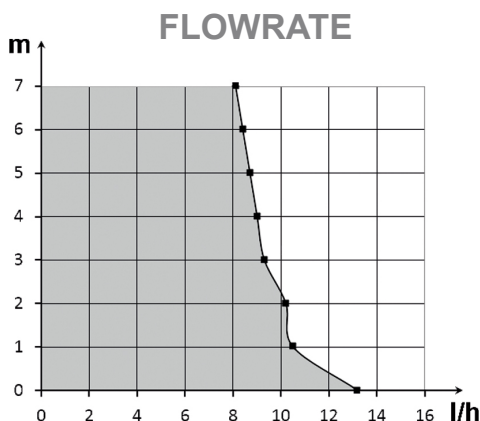

## CONTENTS



Duct with elbow- Finishing gasket - Finishing ceiling plate - Pump ECO FLOWATCH - Reservoir - Inlet tube - Double-side adhesive - Clamps